

# **Alpha 600 Series**

---

**Industrial Radio Remote Control System**

## **Operation & Parts Manual**

**FOMOTECH International Corp.**

# TABLE OF CONTENTS

	Page
1. SAFETY INSTRUCTION .....	3
2. PUSHBUTTON CONFIGURATION	
2.1 Alpha 604 Models .....	4
2.2 Alpha 607 & 608 Models .....	5
2.3 Alpha 612 Models .....	5
3. TRANSMITTER OUTLINE	
3.1 Transmitter Outline .....	6
3.2 Alpha 604/607/608/612 Spare Parts .....	7
3.3 Battery Charger .....	7
4. RECEIVER OUTLINE	
4.1 Alpha 604-608 .....	8
4.1.1 Alpha 604-608 Models External Assembly .....	8
4.1.2 Alpha 604 Models Internal Assembly .....	9
4.1.3 Alpha 607/608 Models Internal Assembly .....	10
4.2 Alpha 612 .....	11
4.2.1 Alpha 612 Models External Assembly .....	11
4.2.2 Alpha 612 Models External/Internal Assembly .....	12
4.3 $\alpha$ 604/ $\alpha$ 608/ $\alpha$ 612 Receiver Power Fuse List .....	13
5. OUTPUT CONTACT DIAGRAMS	
5.1 Alpha 604 Models .....	14
5.2 Alpha 607 Models .....	14
5.3 Alpha 608 Models .....	15
5.4 Alpha 612 Models .....	17
6. SYSTEM CONFIGURATIONS	
6.1 How to Set ID Codes .....	24
6.2 Transmitter RF Channel Setting .....	25
7. RECEIVER SETTING	
7.1 How to Set Receiver ID Codes .....	25
7.2 Receiver RF Channel Settings .....	26
7.3 Receiver Function Settings .....	27
7.3.1 $\alpha$ 604/607/608 Receiver Function Settings .....	27
7.3.2 $\alpha$ 612 Receiver Function Settings .....	28
7.3.3 $\alpha$ 612 Models Dip-Switch Function Table .....	29
7.3.4 $\alpha$ 612 Receiver Voltage Settings .....	31
7.4 Frequency (RF) Channels Table .....	32
8. TRANSMITTER OPERATION & STATUS LIGHT	
8.1 Transmitter Operating Steps .....	34
8.2 Transmitter Status light .....	35
9. RECEIVER INSTALLATION	
9.1 Preparation For Installation .....	36
9.2 Step-By-Step Installation .....	37
9.3 System Testing .....	38
9.4 Receiver System Status LED Display.....	38

10. BATTERY CHARGER	
10.1 Charger Operation .....	40
10.2 Battery Charger LED Status Light .....	42
11. TROUBLE SHOOTING.....	42
12. SYSTEM SPECIFICATION .....	43
13. PARTS LIST .....	45

# 1. SAFETY INSTRUCTION

The Alpha 600 series are relatively simple to use, however, it is very important to observe the proper safety procedures before, during, and after operation. When used properly, the Alpha 600 series will enhance safety, productivity and efficiency in the workplace.

## **The following procedures should be strictly followed:**

1. The transmitter is equipped with an induction battery charger. Only two "AA" Ni-MH rechargeable batteries are allowed to be used in the transmitter. Please note the polarity of the batteries. Do not use other types of battery to prevent any accident.
2. Be sure to replace the batteries with the same brand and specification at the same time. Do not replace only one battery in the battery compartment otherwise there will have the condition of limited transmitter operating time, battery leakage and overheating when charging.
3. Do not place the battery charger under the raining, high temperature, humid and with corroded air environment. Indoor with good ventilation is suggested. Please also do not use the battery charger under 0°C.
4. It is prohibited that the high power wireless equipment such as walkie-talkie, wireless network transmitter, ... etc. is closed to the transmitter or receiver as it might cause interference.
5. Do not change the IDs on transmitter encoder and receiver decoder boards at will.
6. Check the transmitter casing and pushbuttons daily. Should any damage that could inhibit the proper operation of the transmitter be found the unit should be immediately removed from service.
7. Check the transmitter voltage whenever it is operated. Place the transmitter into battery charger when battery is running out or the voltage is low.
8. The red emergency stop button (EMS) should be checked at the beginning of each shift to ensure it is in proper working order and the "Stop" command is being received by the receiver.
9. In the event of an emergency press down the EMS button will immediately deactivates the receiver MAIN relay and the transmitter power. Then turned the power "off" from the main power source to the crane or equipment.
10. Do not use the same RF channel and ID code as any other system in use at the same facility or within 300-meter distance.
11. Ensure the waist belt is worn at all time during operation to avoid accidental damage to the transmitter.
12. Rotate the power switch to OFF position when the transmitter is not operated temporarily or the operation is finished.
13. Any repair or adjustment should be proceeding by repair technician for radio remote controls.
14. The operator should not change any electrical parts at will.

## 2. PUSHBUTTON CONFIGURATION

### 2.1 Alpha 604 Models

1. Alpha 604A -- (4) single speed pushbuttons
2. Alpha 604B -- (4) double speed pushbuttons

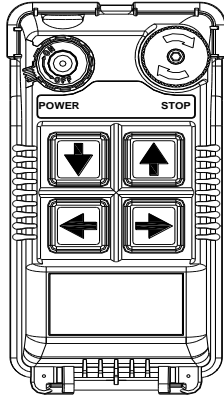

(Alpha 604A)

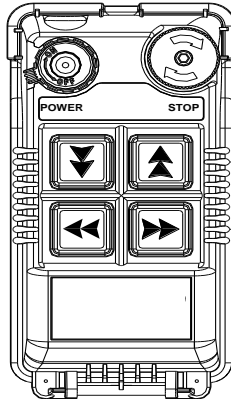

(Alpha 604B)

Below are some of many types of pushbutton configurations that are also available, please contact your dealer for more details.

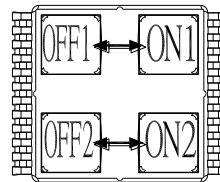
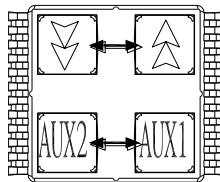
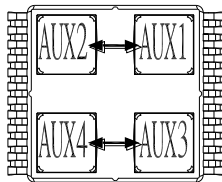
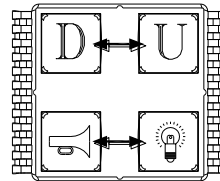
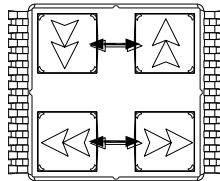
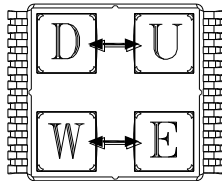

↔ Interlocked (Can also be set to non-interlocked via an external programmer unit).

## 2.2 Alpha 607 & 608 Models

- |                |    |   |
|----------------|----|---|
| 1. Alpha 607A  | -- | (7) single speed pushbuttons  |
| 2. Alpha 607B  | -- | (6) double speed pushbuttons + (1) single speed pushbuttons                             |
| 3. Alpha 607AT | -- | (6) single speed pushbuttons + (1) SELECT I/II pushbutton                               |
| 4. Alpha 607BT | -- | (6) double speed pushbuttons + (1) SELECT I/II pushbutton                               |
| 5. Alpha 608A  | -- | (8) single speed pushbuttons  |
| 6. Alpha 608B  | -- | (6) double speed pushbuttons + (2) single speed pushbuttons                             |
| 7. Alpha 608AT | -- | (7) single speed pushbuttons + (1) SELECT I/II pushbutton                               |
| 8. Alpha 608BT | -- | (6) double speed pushbuttons + (1) single speed pushbutton + (1) SELECT I/II pushbutton |

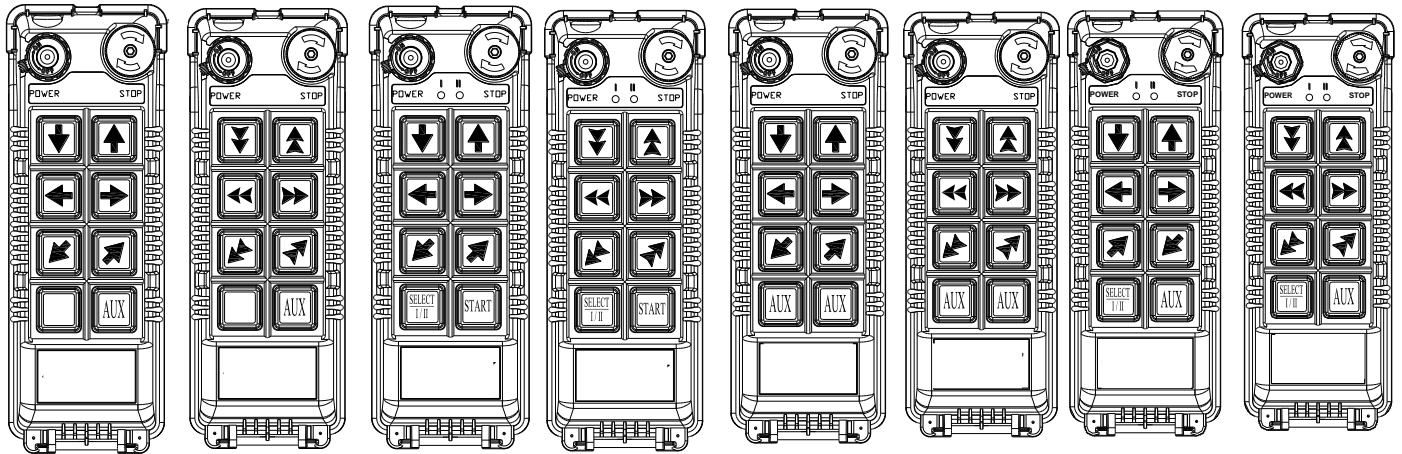

(Alpha 607A) (Alpha 607B) (Alpha 607AT) (Alpha 607BT) (Alpha 608A) (Alpha 608B) (Alpha 608AT) (Alpha 608BT)

## 2.3 Alpha 612 Models

- |                 |   |   |
|-----------------|---|---|
| 1. Alpha 612A   | → | (12) one-speed pushbuttons  |
| 2. Alpha 612B   | → | (11) one-speed pushbuttons + I/II select pushbutton*                |
| 3. Alpha 612C-1 | → | (6) two-speed + (6) one-speed pushbuttons                           |
| 4. Alpha 612C-2 | → | (8) two-speed + (4) one-speed pushbuttons                           |
| 5. Alpha 612D   | → | (10) two-speed + (2) one-speed pushbuttons                          |
| 6. Alpha 612E-1 | → | (6) two-speed + (5) one-speed pushbuttons + I/II select pushbutton* |
| 7. Alpha 612E-2 | → | (8) two-speed + (3) one-speed pushbuttons + I/II select pushbutton* |

\* For cranes with auxiliary hoist and trolley (changeover function).

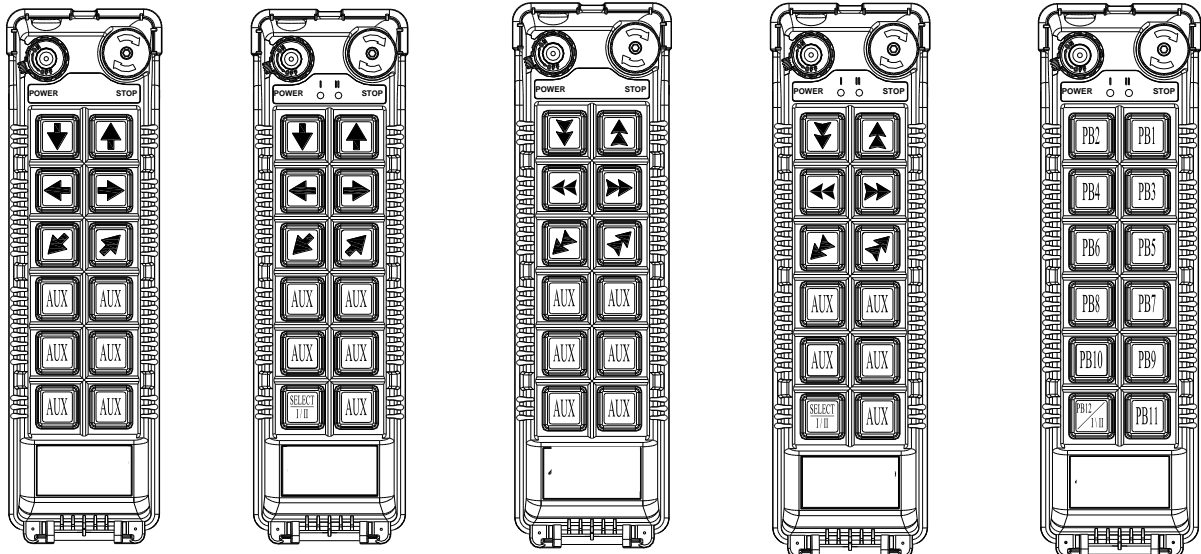

Alpha 612A

Alpha 612B

Alpha 612C-1  
Alpha 612C-2  
Alpha 612D

Alpha 612E-1  
Alpha 612E-2

Alpha 612 button  
reference

### 3. TRANSMITTER OUTLINE

#### 3.1 Transmitter Outline

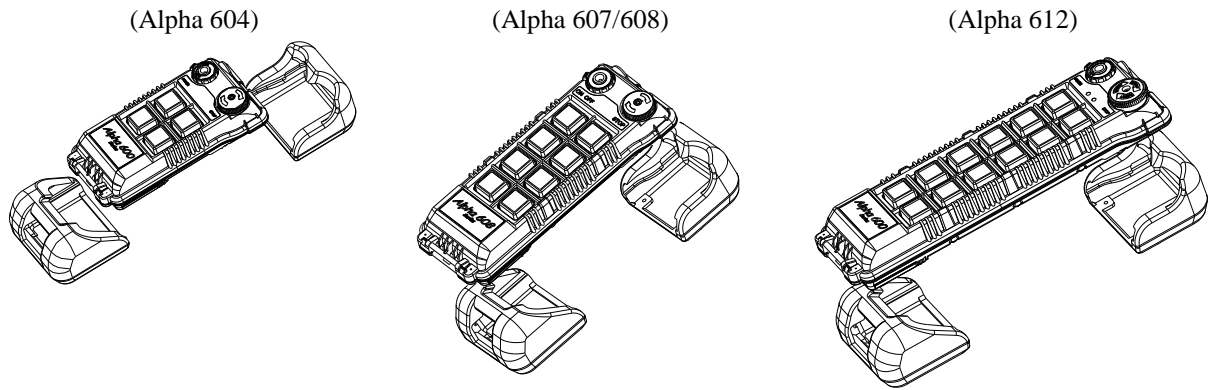

(Fig.1) Transmitter Front View

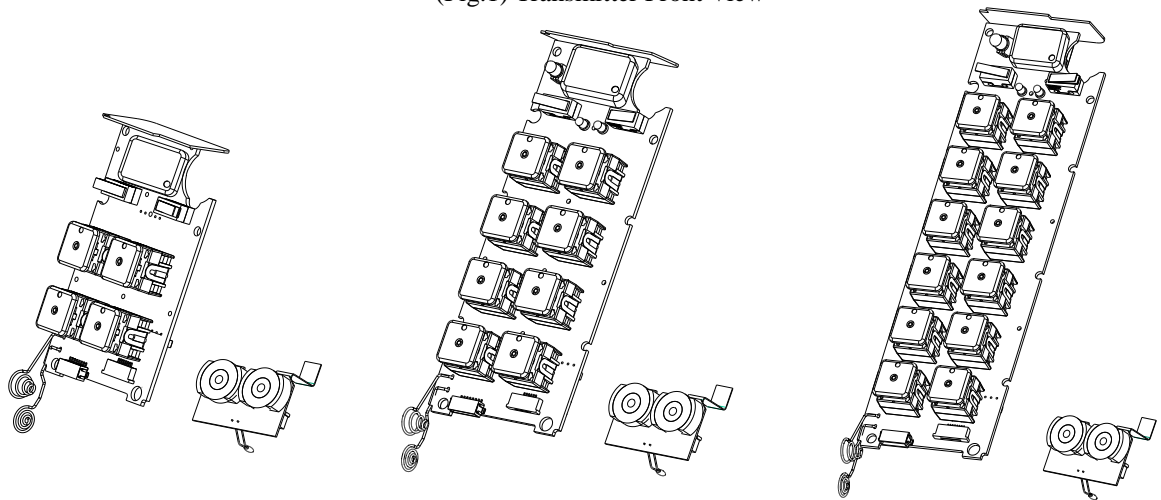

(Fig.2) Transmitter encoder board and induction charging board

(Fig.3) Transmitter Internal Assembly:

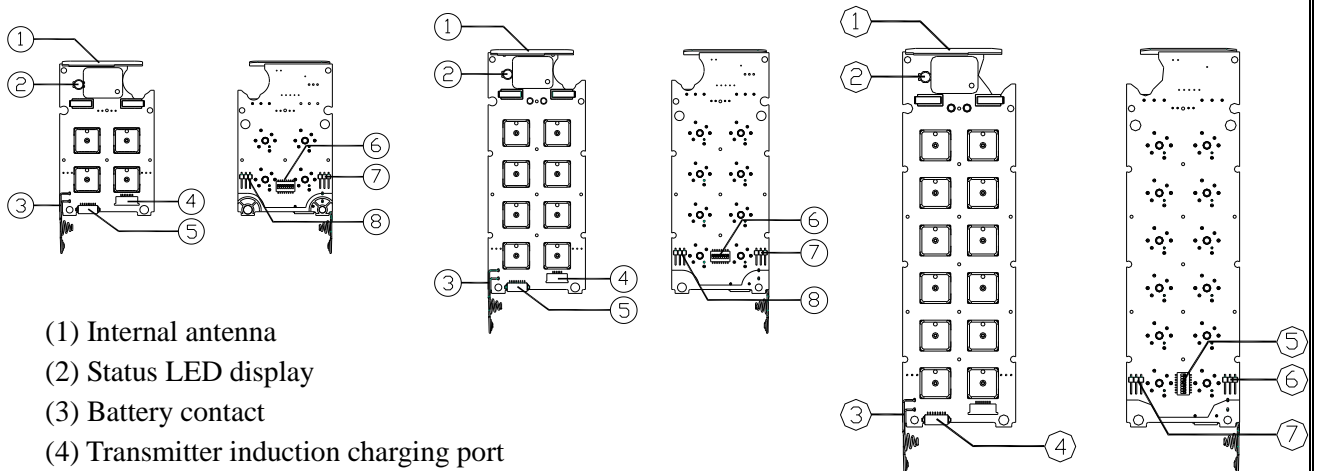

- (1) Internal antenna
- (2) Status LED display
- (3) Battery contact
- (4) Transmitter induction charging port
- (5) Programming port
- (6) Function dip-switch
- (7) JP2 setting pin
- (8) JP1 setting pin

### 3.2 Alpha 604/607/608/612 Spare Parts

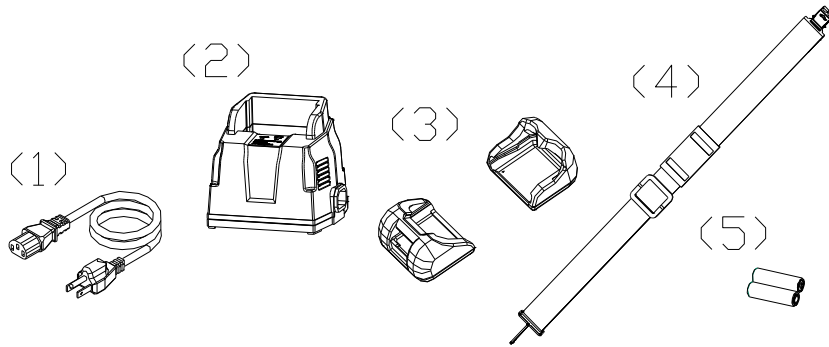

- (1) Charging cable
- (2) Charger (*optional*)
- (3) Transmitter shock-absorbing rubber
- (4) Shoulder strap
- (5) Rechargeable batteries (*optional*)

### 3.3 Battery Charger

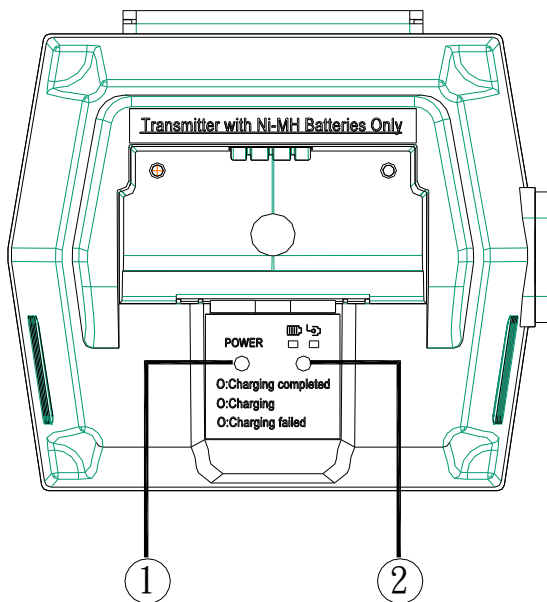

- (1) Charger power status: green light
- (2) Charging status: green/red light
- (3-1) Power input socket AC100-240V
- (3-2) Power input socket DC12-24V
- (4) Charger holder (*optional*). Please refer to below figure for the installation holes.

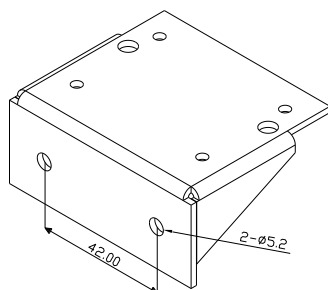

(Fig.4) Battery Charger & Holder

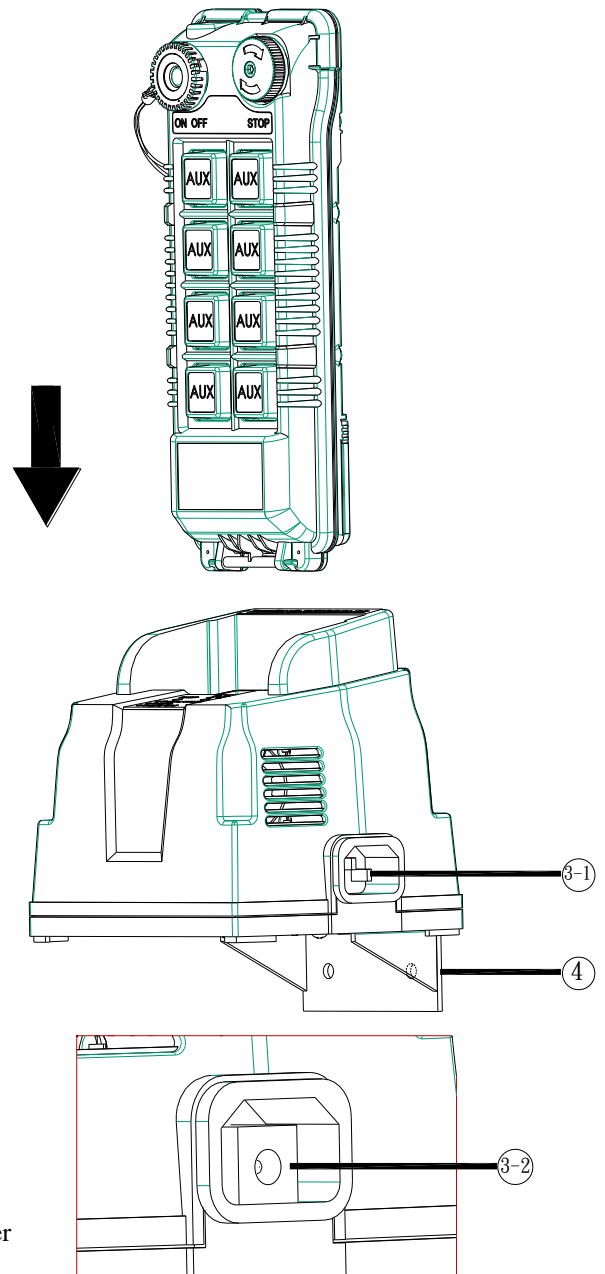



## 4. RECEIVER OUTLINE

### 4.1 Alpha 604 ~ 608

#### 4.1.1 Alpha 604 ~ 608 Models External Assembly

SIZE : 310mm X 134mm X 72mm

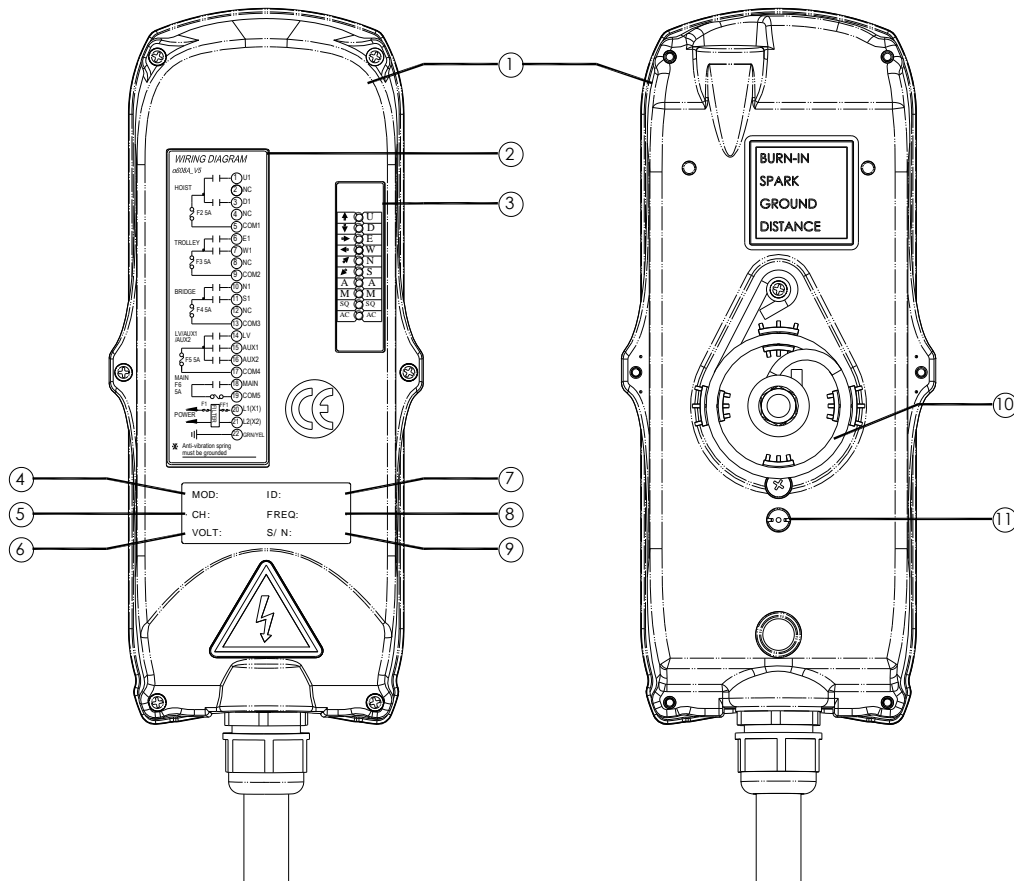

(Fig.5) Front View

(Fig.6) Back View

- |                           |                      |                           |
|---------------------------|----------------------|---------------------------|
| 1) Receiver enclosure     | 5) System frequency  | 9) System serial number   |
| 2) Wiring diagram         | 6) Supplied voltage  | 10) Anti-vibration spring |
| 3) Receiver LED displays* | 7) System ID code    | 11) Grounding (GND)       |
| 4) Type model             | 8) System RF channel |                           |

\* **A** ~ AUX Relay Contact Indicator (for Alpha 607A /608B models only).

\* **M** ~ MAIN and 2<sup>nd</sup> Speed Relay Contact Indicator.

Green "on" → MAIN activated (All models).

Red "on" → 2<sup>nd</sup> speed activated (for Alpha 608B model only).

\* **SQ** ~ RF Signal Indicator (Red).

"on" → RF signal detected and received.

"off" → No RF signal detected or received.

Blinking at transmitter power "off" → Other radio interference.

\* **AC** ~ Power Source Indicator (red) "on" → AC input power supplied.

"off" → No AC input power.

## 4.1.2 Alpha 604 Internal Assembly

(Fig. 7) Internal Parts Assembly

- 1) Receiving RF module
- 2) External programming port
- 3) Power module \*
- 4) Secondary power AC fuse (F1)
- 5) Primary power AC fuse (FF1)
- 6) Internal Antenna
- 7) System status LED display\*
- 8) External antenna port
- 9) ID code dip-switch
- 10) RF channel dip-switch
- 11) Contact relay LED display
- 12) Pushbutton #1 and #2 fuse (5.0A)
- 13) MAIN fuse (5.0A)
- 14) Contact output seat (CN3)
- 15) Low-voltage (LV) fuse (5.0A)
- 16) Contact output seat (CN4)
- 17) Pushbutton #3 and #4 fuse (5.0A)
- 18) AC power input seat (CN2)
- 19) Cable gland & output cable

\* Power module: Including transformer or full-voltage module.

\* Please refer to 4.3  $\alpha$  604/  $\alpha$  608/  $\alpha$  612 Receiver Power Fuse List.

\*Please refer to page 39 for system status LED display information.

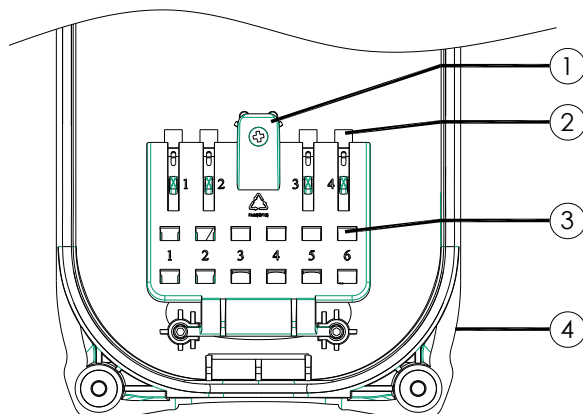
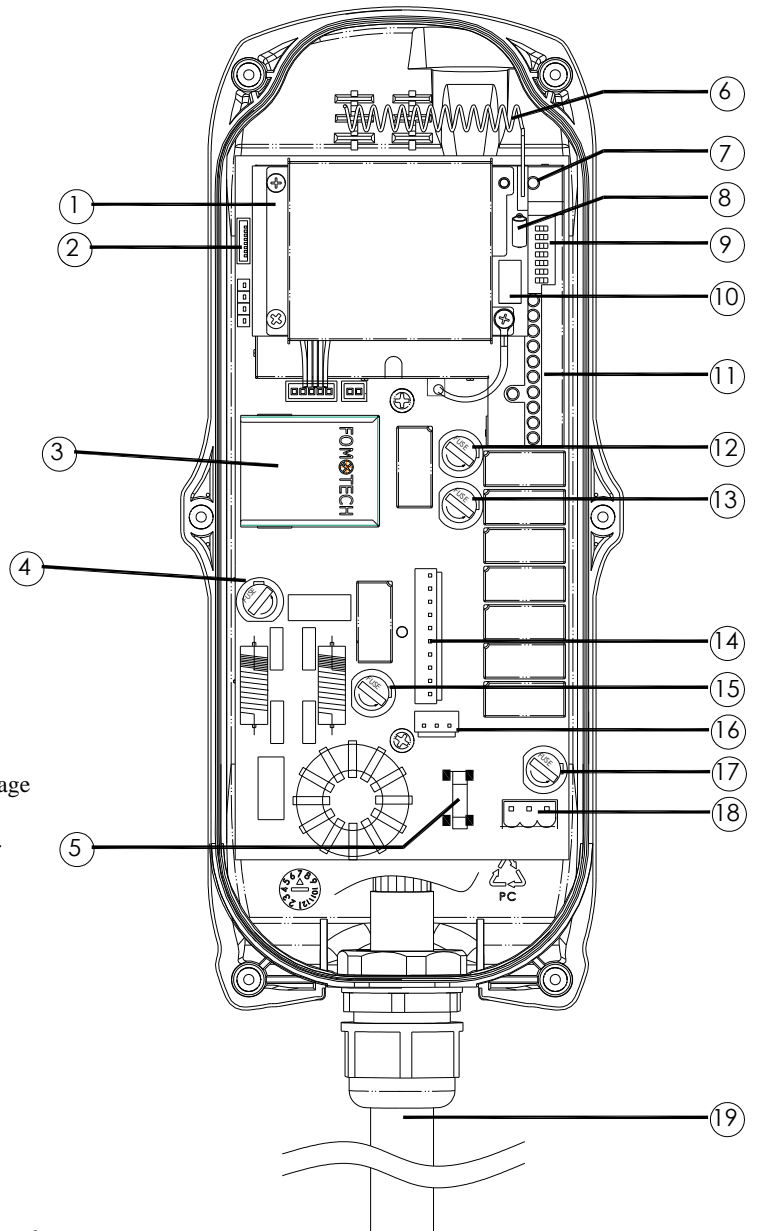

- (1) Spare fuse & jumper compartment
- (2) Spare Jumper slots
- (3) Spare fuse slots
- (4) Receiver top casing

### 4.1.3 Alpha 608 Internal Assembly

- 1) Receiving RF module
- 2) External programming port
- 3) Power module
- 4) Secondary power AC fuse (F1)
- 5) Contact output seat (CN8)
- 6) Primary power AC fuse (FF1)
- 7) AC power input seat (CN2)
- 8) Internal Antenna
- 9) System Status LED display\*
- 10) External antenna port
- 11) ID code dip-switch
- 12) RF channel dip-switch
- 13) Contact relay LED display
- 14) Pushbutton #1 and #2 fuse (5.0A)
- 15) Contact output seat (CN3)
- 16) MAIN contact fuse (5.0A)
- 17) Pushbutton #3 and #4 fuse (5.0A)
- 18) Pushbutton #5 and #6 fuse (5.0A)
- 19) Contact output seat (CN4)
- 20) LV & AUX fuse (5.0A)
- 21) Cable gland & output cable

\* Power module: Including transformer or full-voltage module.

\* Please refer to 4.3  $\alpha$  604/  $\alpha$  608/  $\alpha$  612 Receiver Power Fuse List.

\*Please refer to page 39 for system status LED display information.

(Fig. 8) Internal Parts Assembly

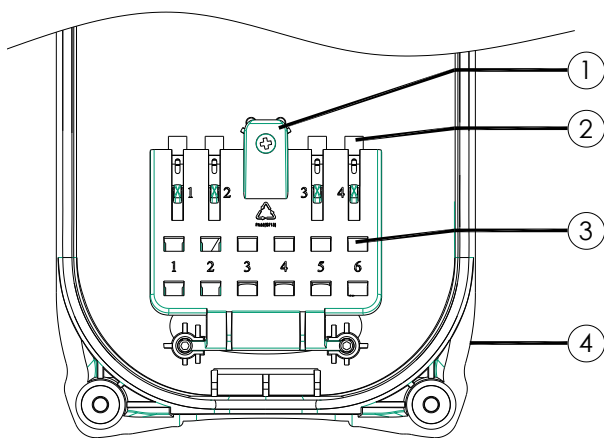
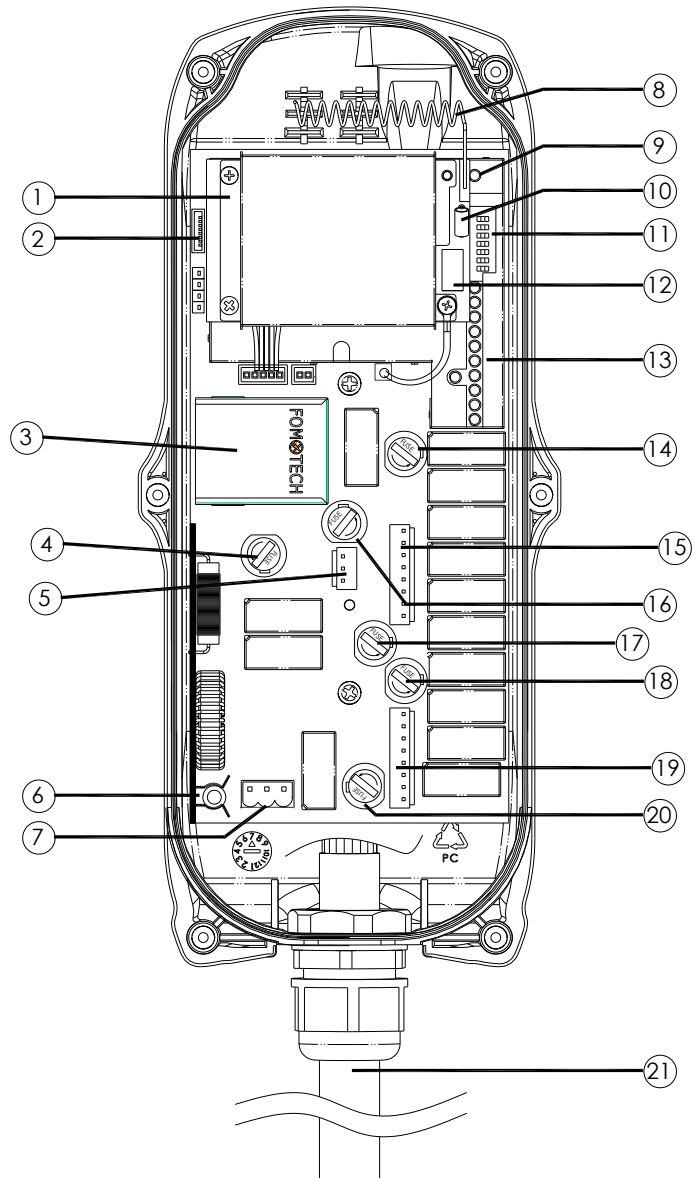

- 1) Spare fuse & jumper compartment
- 2) Spare Jumper slots
- 3) Spare fuse slots
- 4) Receiver top casing

## 4.2 Alpha 612

### 4.2.1 Alpha 612 External Assembly

SIZE : 300mm X 230mm X 86mm

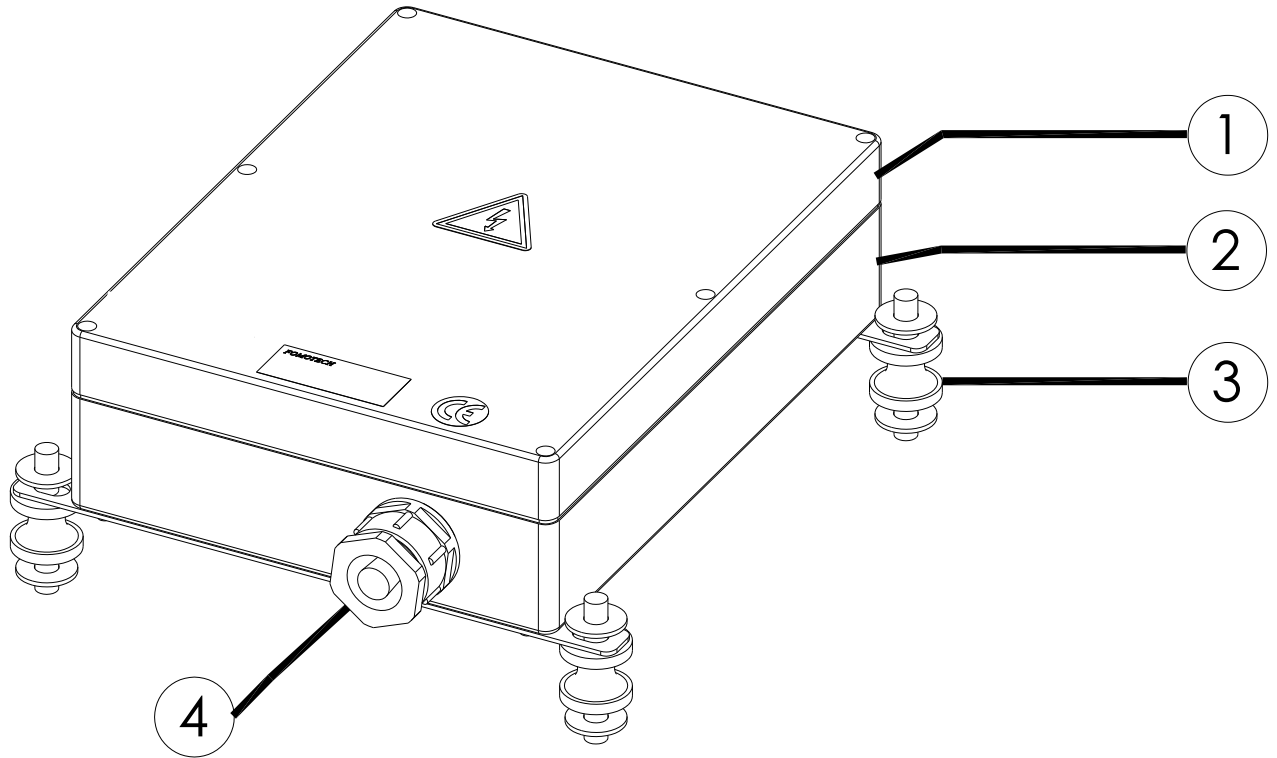

(Fig. 9) External Parts Assembly

- |                            |  |
|----------------------------|--|
| 1) Transparent top cover   | 3) Mounting bracket with shock absorbers |
| 2) Light-gray colored base | 4) Cable gland / Cord grip               |

## 4.2.2 Alpha 612 Internal Assembly

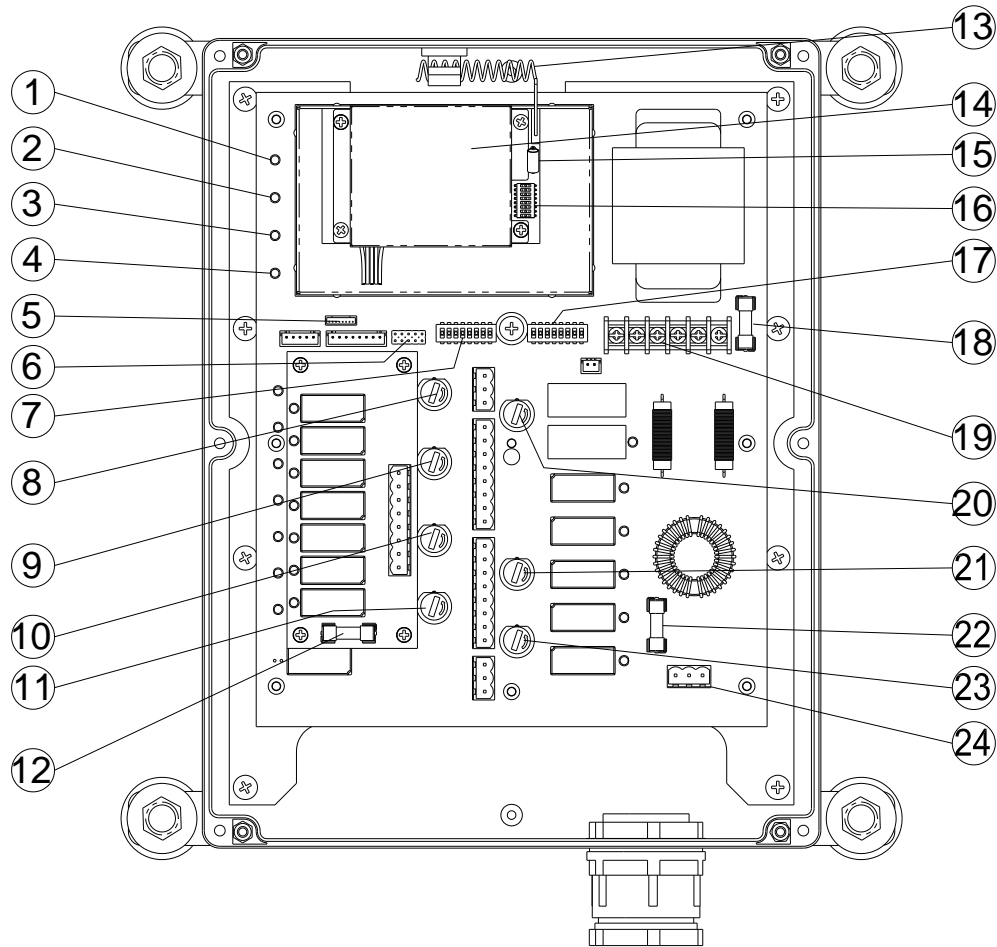

(Fig. 10) Internal Parts Assembly

- |  |  |
|--|--|
| 1) Power LED display*                      | 13) Internal Antenna                                       |
| 2) SQ LED display**                        | 14) Receiving RF module                                    |
| 3) Status LED display****                  | 15) External antenna port                                  |
| 4) DC power relay LED display***           | 16) RF channel dip-switch                                  |
| 5) Programming port                        | 17) ID code dip-switch                                     |
| 6) Jumper settings                         | 18) Secondary power fuse F1*(refer to power fuse list 4.3) |
| 7) Function dip-switch                     | 19) Voltage selector seat                                  |
| 8) Pushbutton #3 and #4 relay fuse (5.0A)  | 20) MAIN relay fuse (5.0A)                                 |
| 9) Pushbutton #5 and #6 relay fuse (5.0A)  | 21) Pushbutton A4 relay fuse (5.0A)                        |
| 10) Pushbutton A1 and A2 relay fuse (5.0A) | 22) Primary power fuse FF1*(refer to power fuse list 4.3)  |
| 11) Pushbutton A3 relay fuse (5.0A)        | 23) Low-voltage (LV) relay fuse (5.0A)                     |
| 12) Pushbutton #1 and #2 relay fuse (5.0A) | 24) Power port CN2   |

\* **POWER** ~ AC Power Source Indicator "on" → AC input power supplied.  
 "off" → No AC input power.

\*\* **SQ** ~ RF Signal Indicator "on" → RF signal detected and received.  
 "off" → No RF signal detected or received.

Blinking at transmitter power "off" → Other radio interference.

\*\*\* **RELAY\_COM** ~ DC Power Source to Relays "on" → DC power to relays.  
 "off" → No DC power to relays.

\*\*\*\* **STATUS** ~ Receiver System Status LED Display → Please refer to page 39.

### 4.3 $\alpha$ 604/ $\alpha$ 608/ $\alpha$ 612 Receiver Power Fuse List

Type	Parts No.	Voltage						
		DC12V~24V	AC24	AC36~48V	AC100~120 V	AC220~240 V	AC380~440 V	AC100~240V Full-Voltage
$\alpha$ 604 $\alpha$ 608	FF1	3A			1A			2A
	F1	3A	2A		0.5A			1A
$\alpha$ 612	FF1	3A			1A			
	F1	3A	2A		0.8A			

# 5. OUTPUT CONTACT DIAGRAMS

## 5.1 Alpha 604 Models

(Alpha 604A)

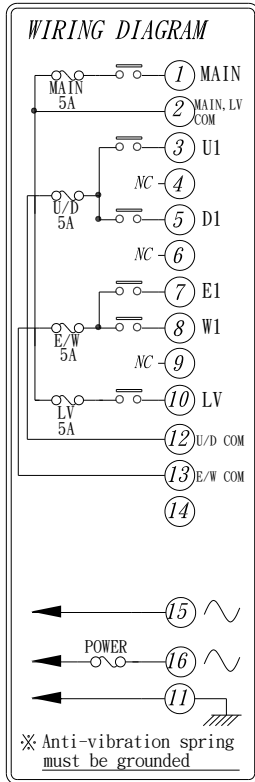

(Alpha 604B)

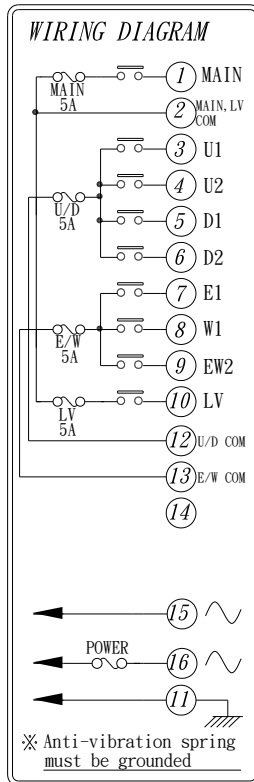

PB1. 1  
PB2. 1  
PB3. 1  
PB4. 1

PB1. 1  
PB1. 2  
PB2. 1  
PB2. 2  
PB3. 1  
PB4. 1  
PB3. 2+4. 2

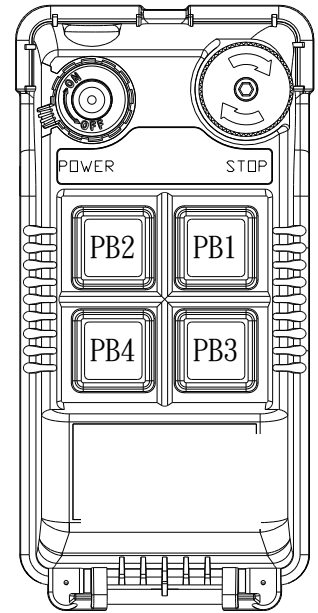

## 5.2 Alpha 607 Models

(Alpha 607A)

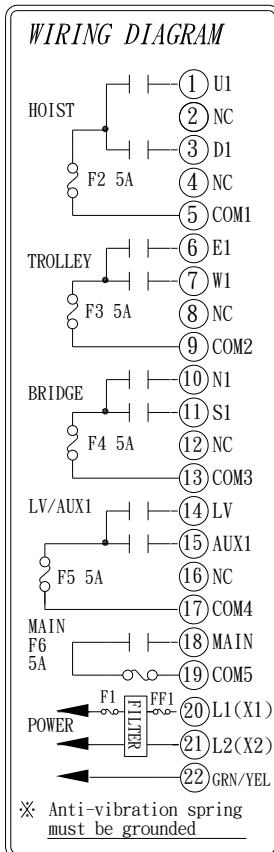

(Alpha 607B)

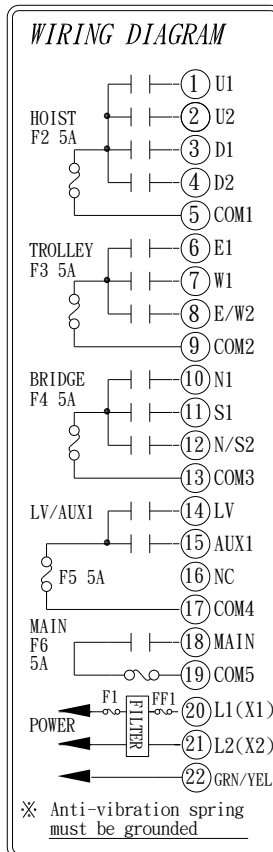

PB1. 1  
PB2. 1  
PB3. 1  
PB4. 1  
PB5. 1  
PB6. 1  
PB7. 1

PB1. 1  
PB1. 2  
PB2. 1  
PB2. 2  
PB3. 1  
PB4. 1  
PB3. 2+4. 2  
PB5. 1  
PB6. 1  
PB5. 2+6. 2  
PB7. 1

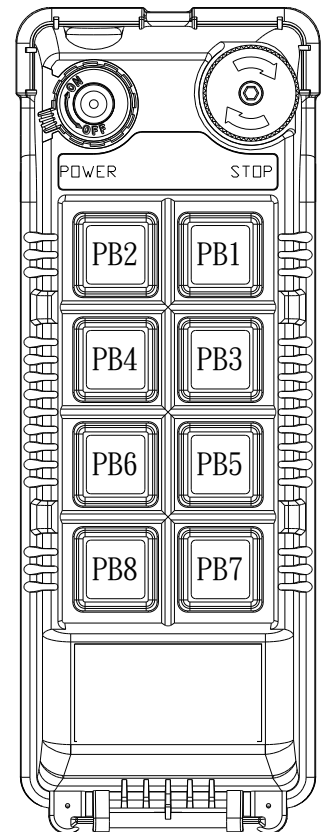

(Alpha 607AT)

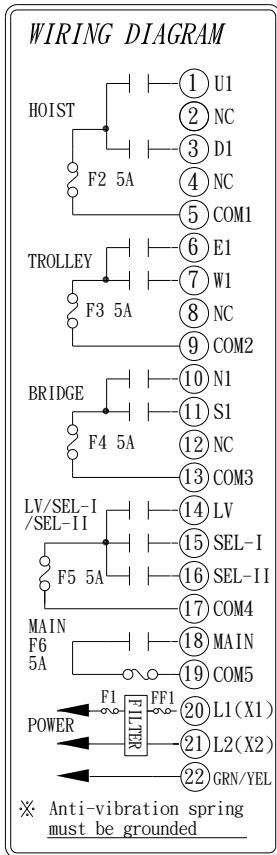

- PB1. 1
- PB2. 1
- PB3. 1
- PB4. 1
- PB5. 1
- PB6. 1
- PB8. I
- PB8. II

(Alpha 607BT)

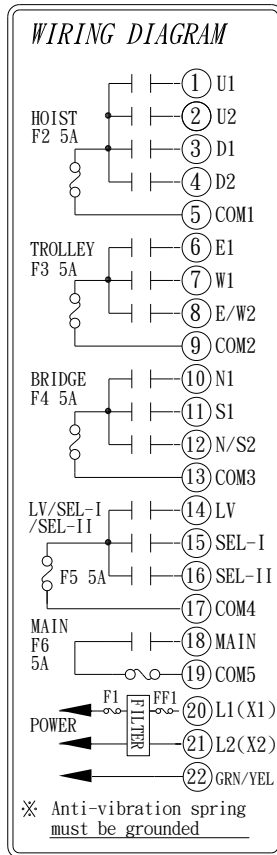

- PB1. 1
- PB1. 2
- PB2. 1
- PB2. 2
- PB3. 1
- PB4. 1
- PB3. 2+4. 2
- PB5. 1
- PB6. 1
- PB5. 2+6. 2
- PB8. I
- PB8. II

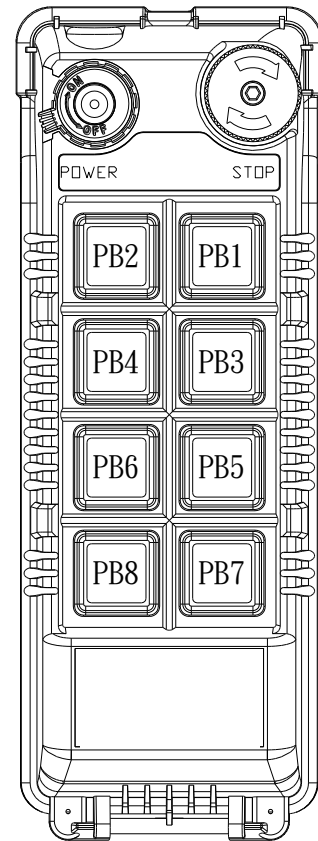

### 5.3 Alpha 608 Models

(Alpha 608A)

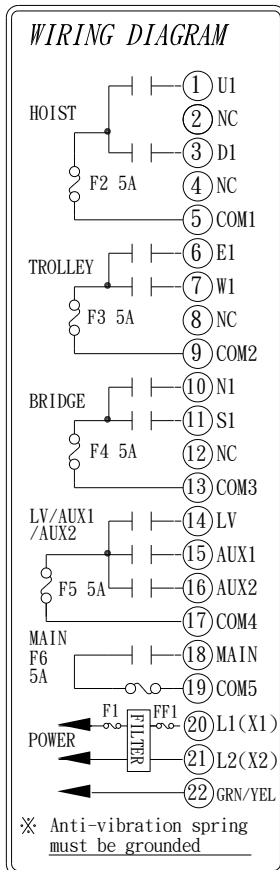

- PB1. 1
- PB2. 1
- PB3. 1
- PB4. 1
- PB5. 1
- PB6. 1
- PB7. 1
- PB8. 2

(Alpha 608B)

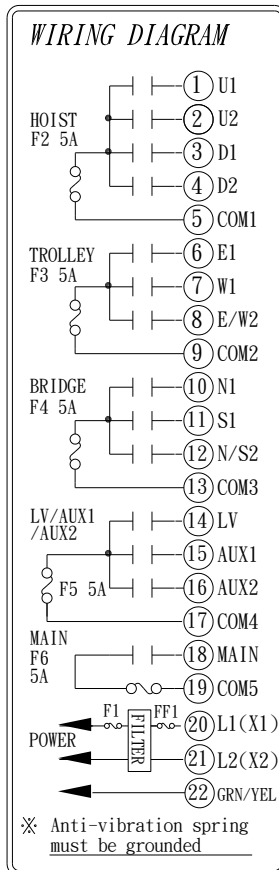

- PB1. 1
- PB1. 2
- PB2. 1
- PB2. 2
- PB3. 1
- PB4. 1
- PB3. 2+4. 2
- PB5. 1
- PB6. 1
- PB5. 2+6. 2
- PB7. 1
- PB8. 2

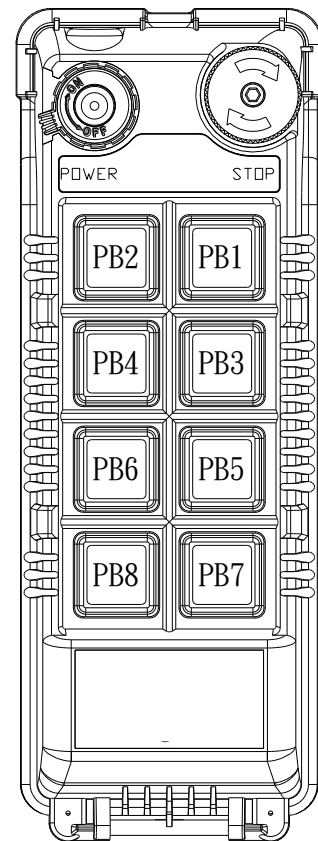



(Alpha 608AT)

WIRING DIAGRAM

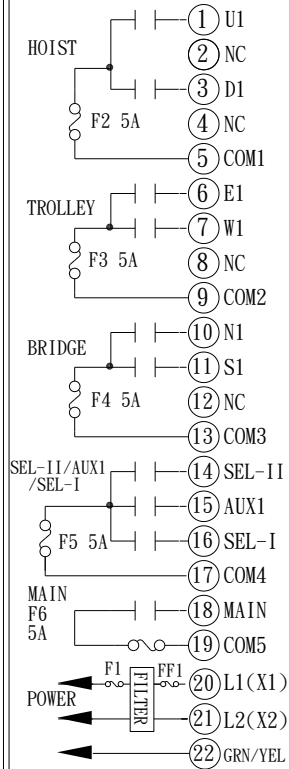

※ Anti-vibration spring must be grounded

PB1. 1

PB2. 1

PB3. 1

PB4. 1

PB5. 1

PB6. 1

PB8. II

PB7. 1

PB8. I

(Alpha 608BT)

WIRING DIAGRAM

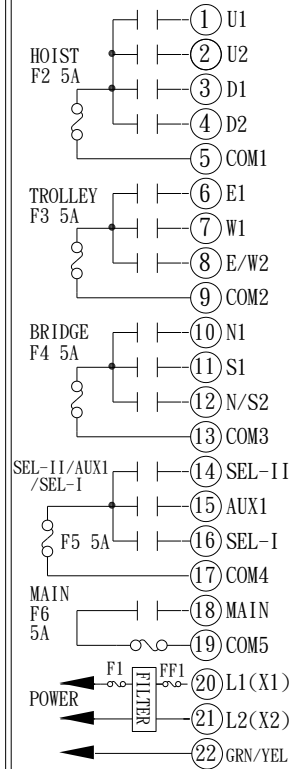

※ Anti-vibration spring must be grounded

PB1. 1

PB1. 2

PB2. 1

PB2. 2

PB3. 1

PB4. 1

PB3. 2+4. 2

PB5. 1

PB6. 1

PB5. 2+6. 2

PB8. II

PB7. 1

PB8. I

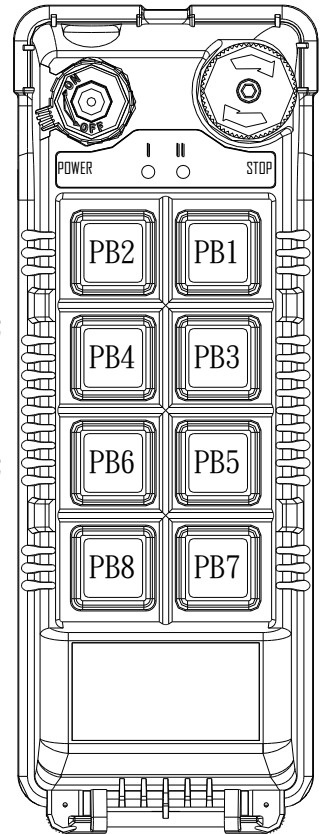

# 5.4 Alpha 612 Models

(Alpha 612A)

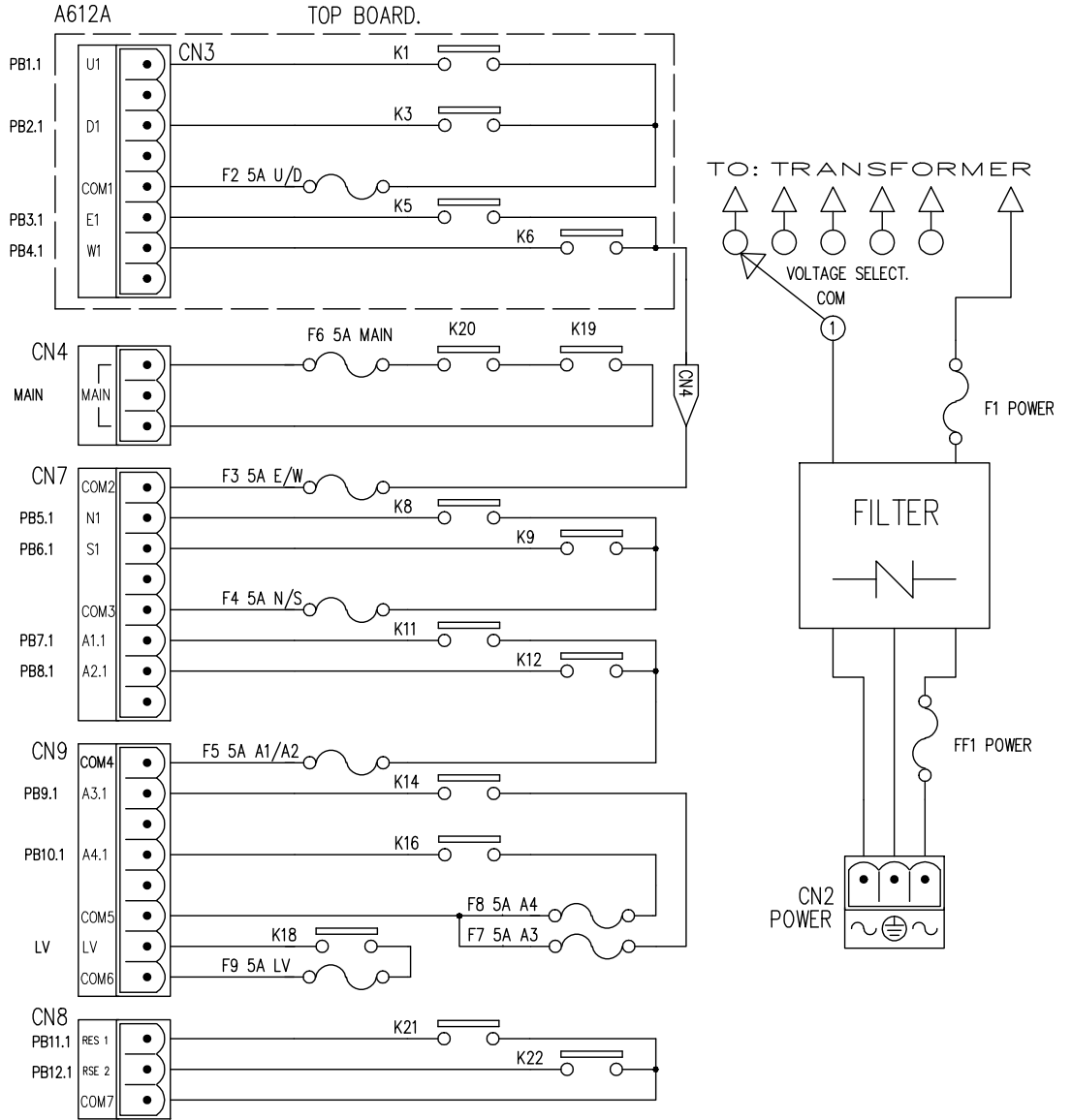
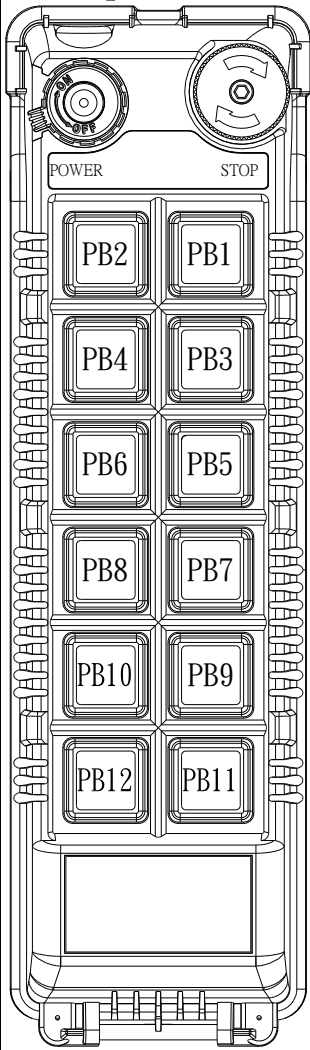

**(Alpha 612B)**

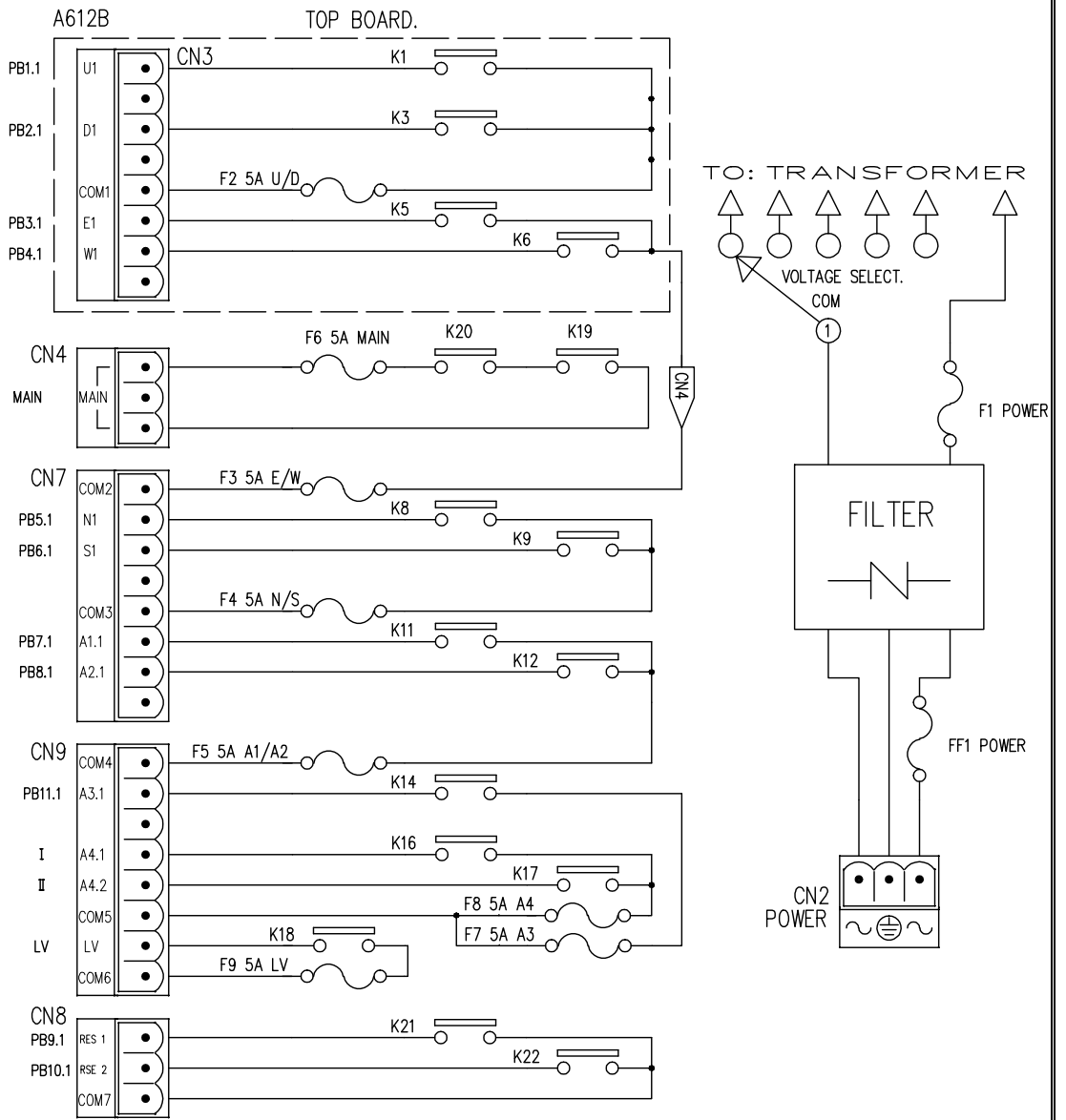
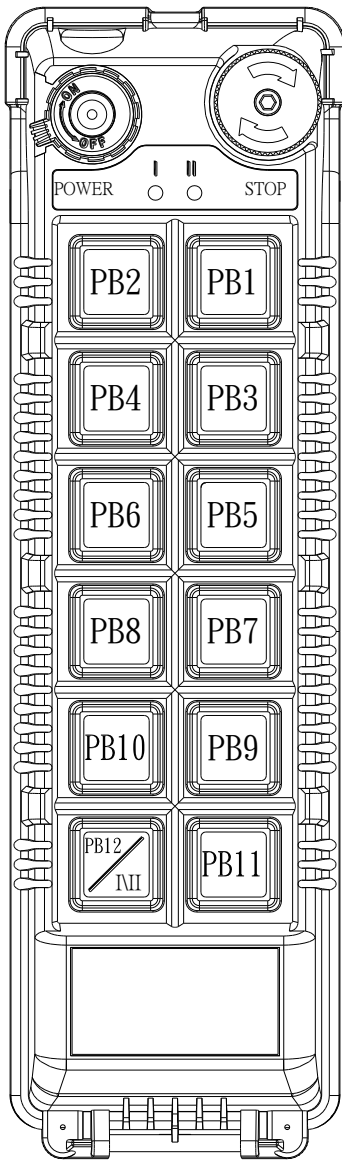

# Alpha 612C-1

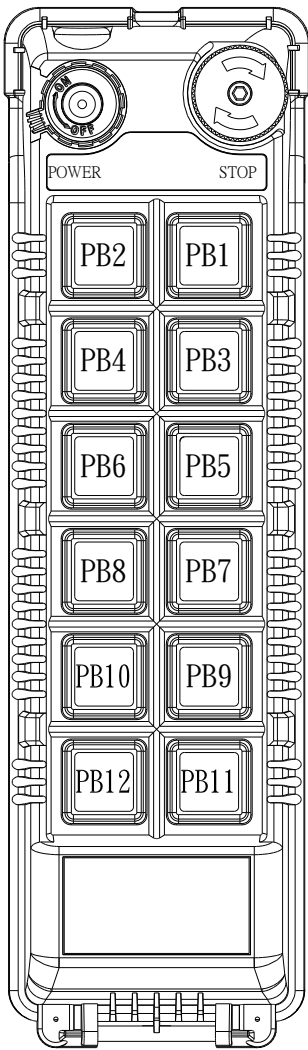

## A612C-1 TOP BOARD.

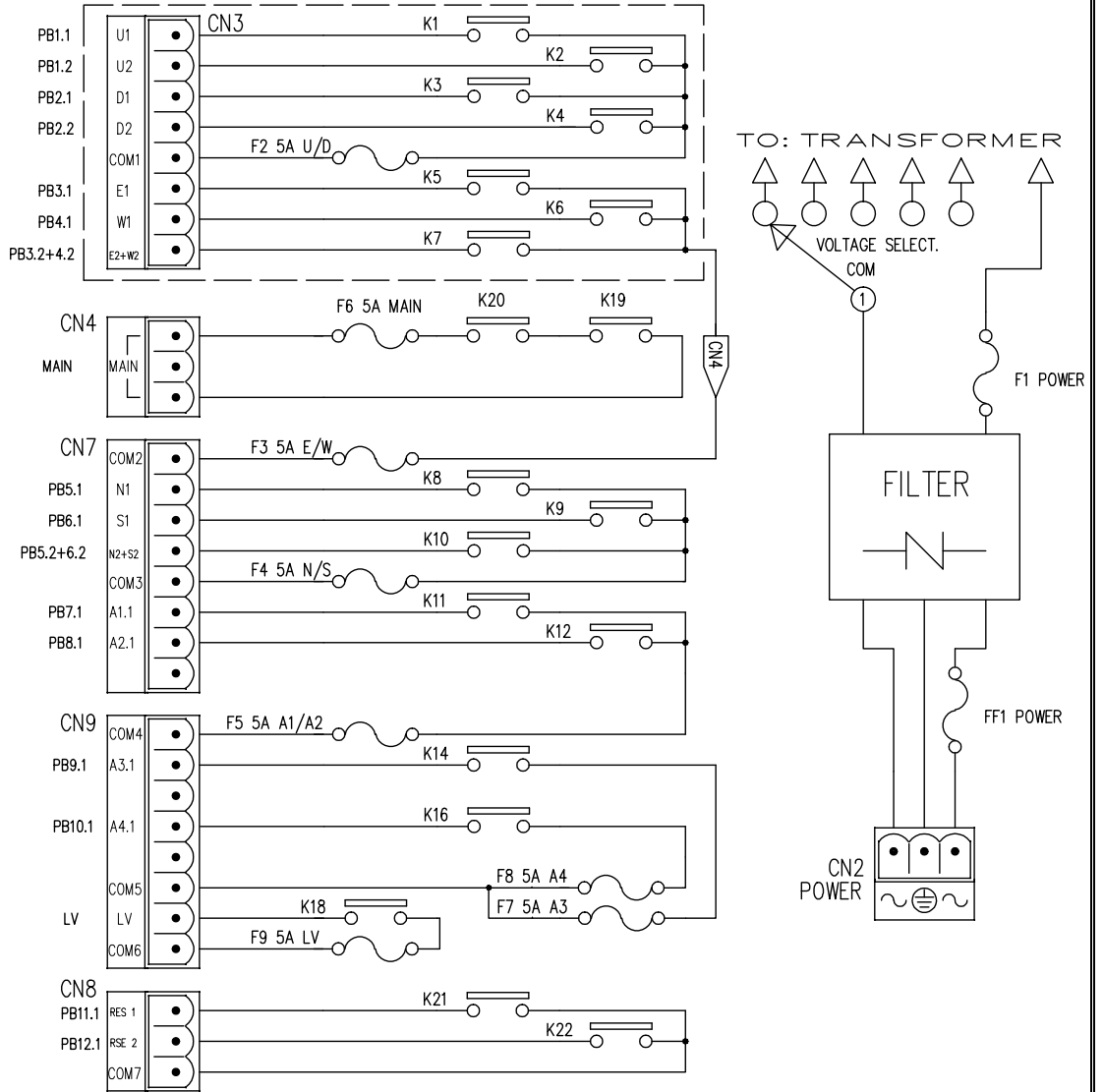

# Alpha 612C-2

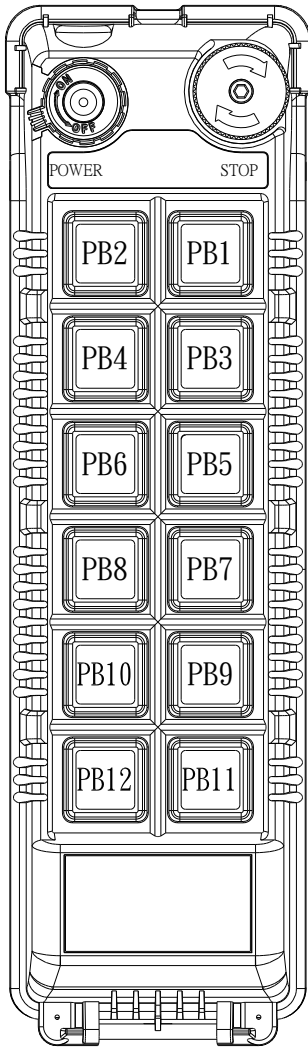

## A612C-2 TOP BOARD.

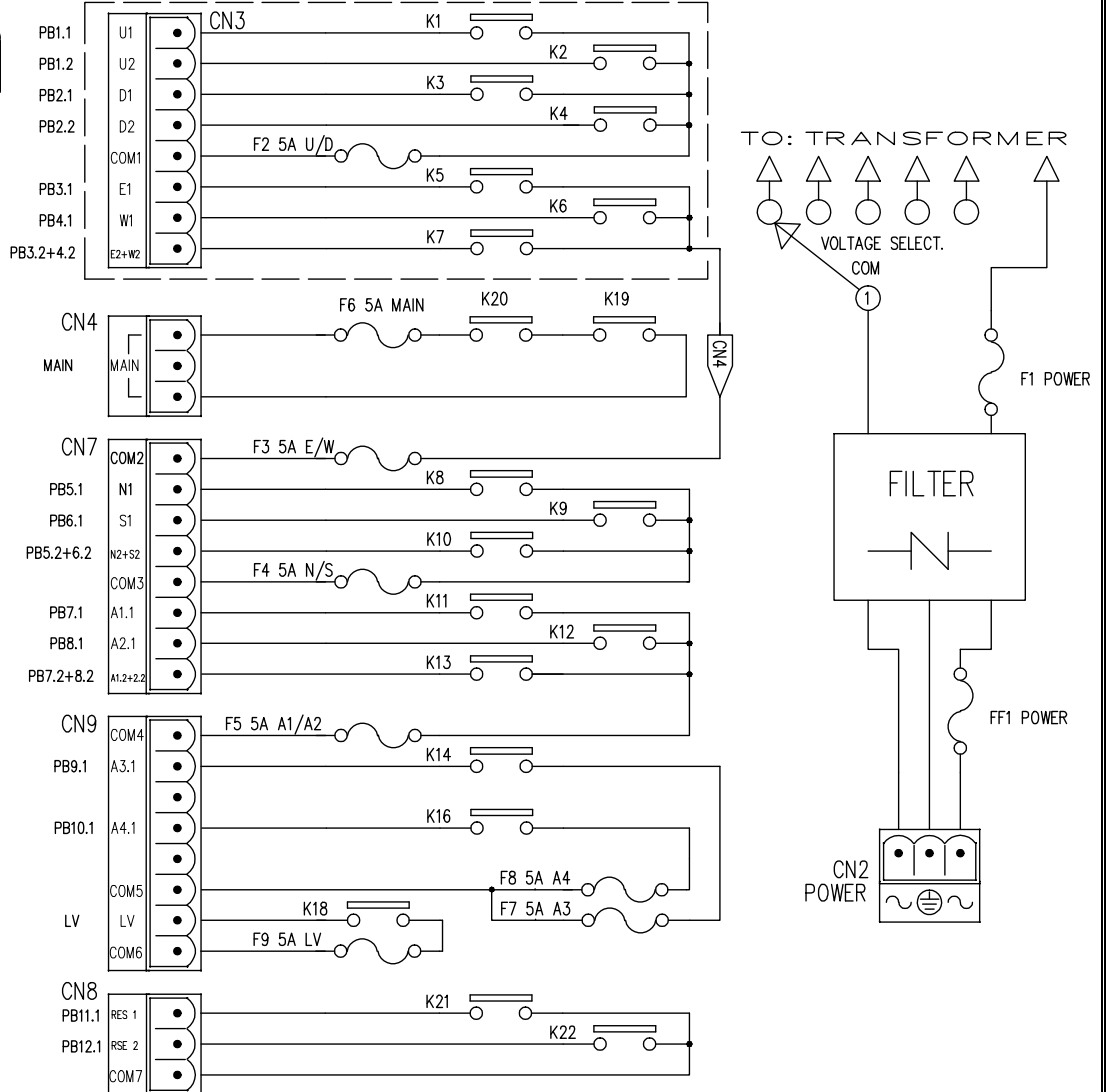

# Alpha 612D

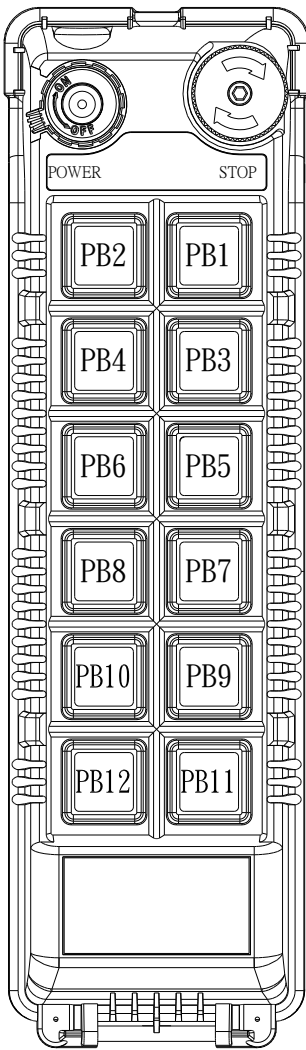

## A612D TOP BOARD.

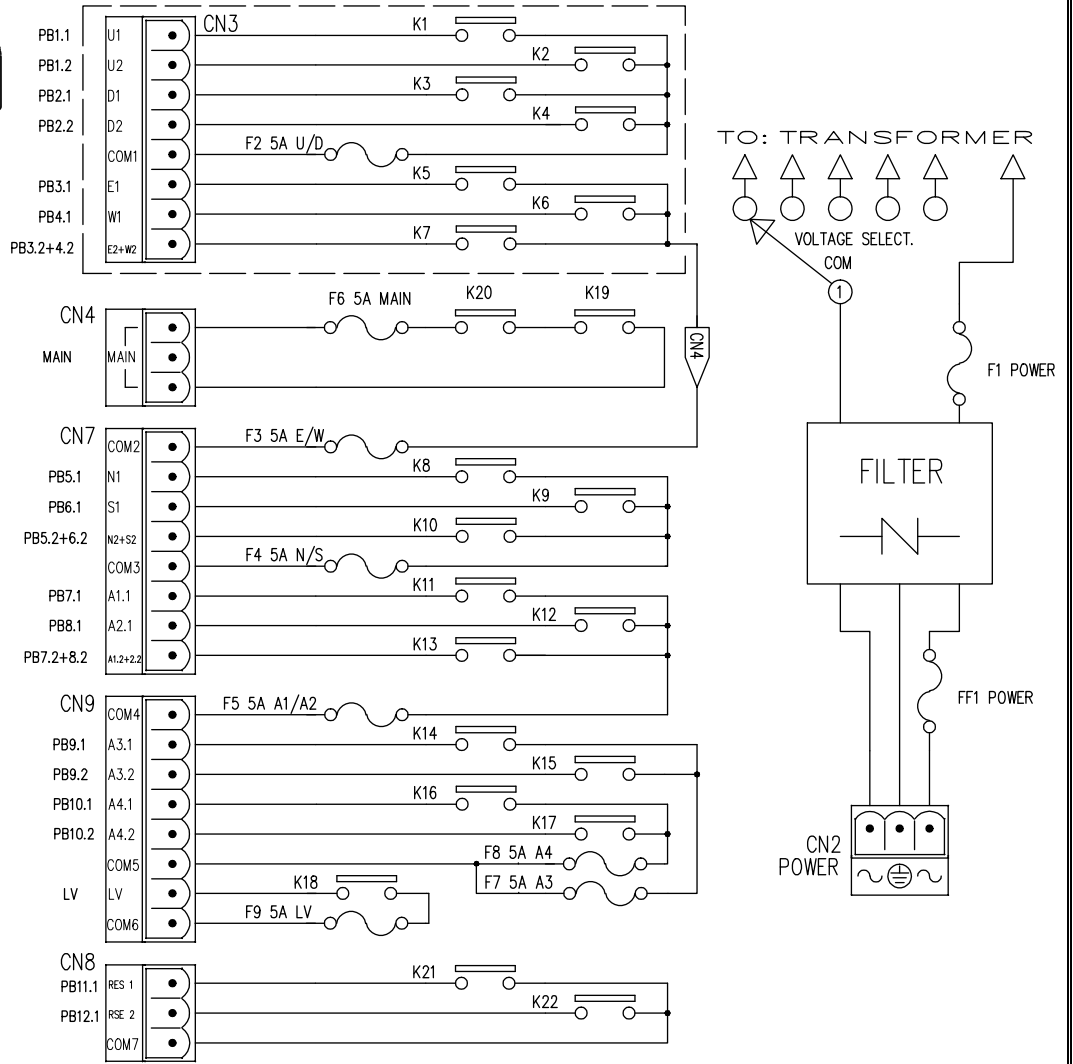

# Alpha 612E-1

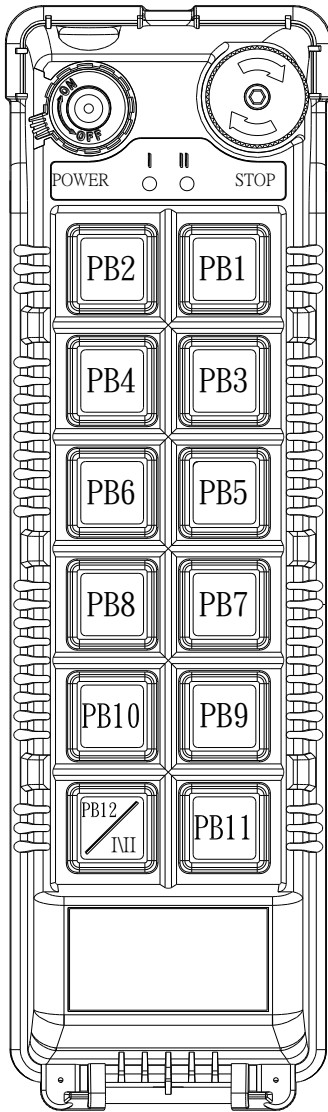

## A612E-1 TOP BOARD.

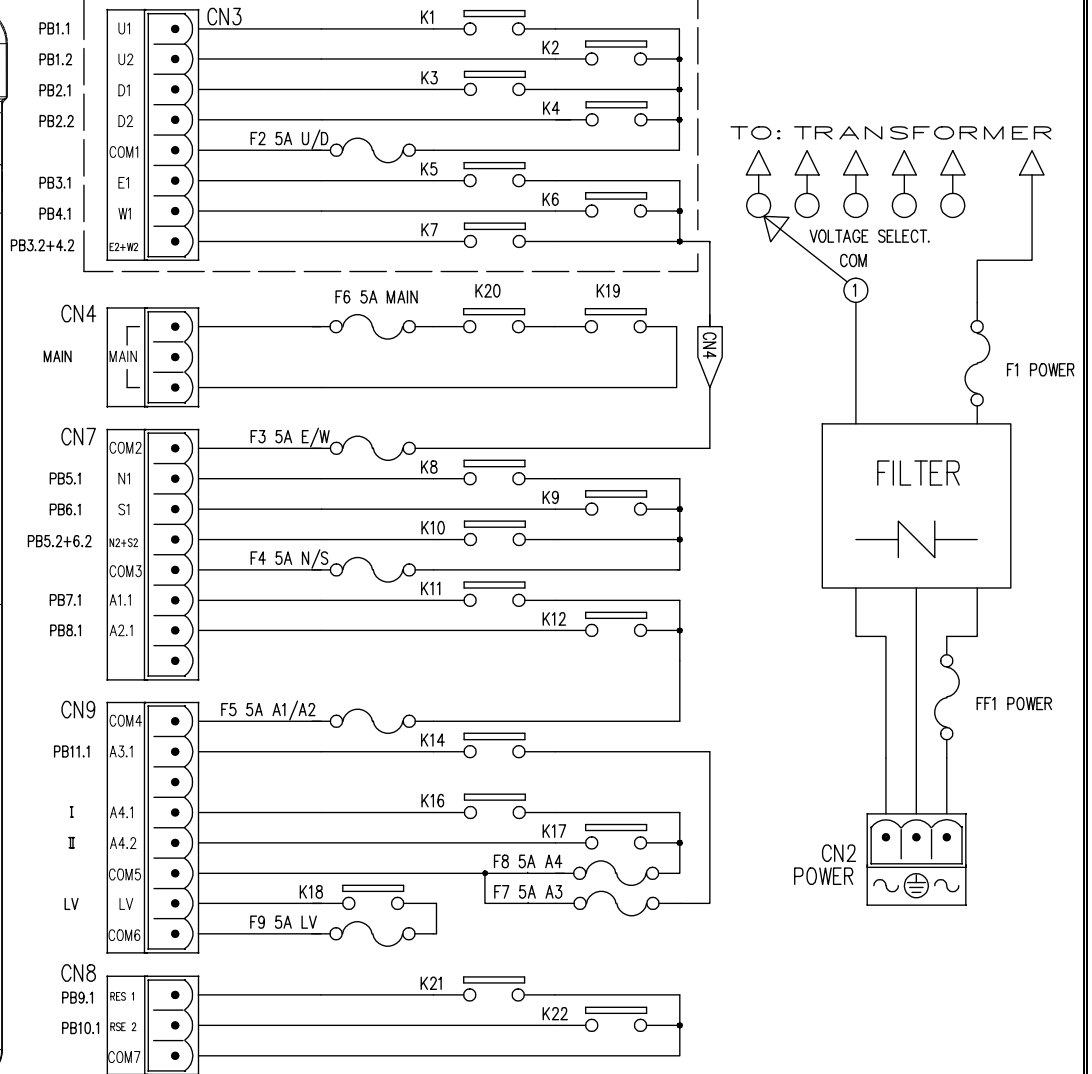

# Alpha 612E-2

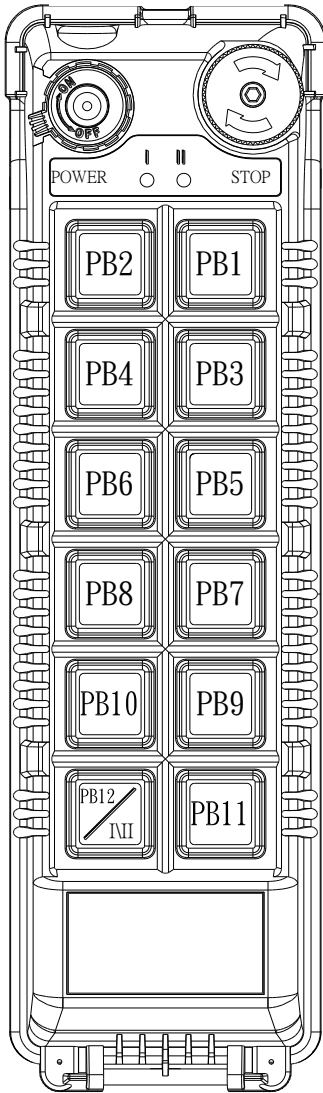

## A612E-2 TOP BOARD.

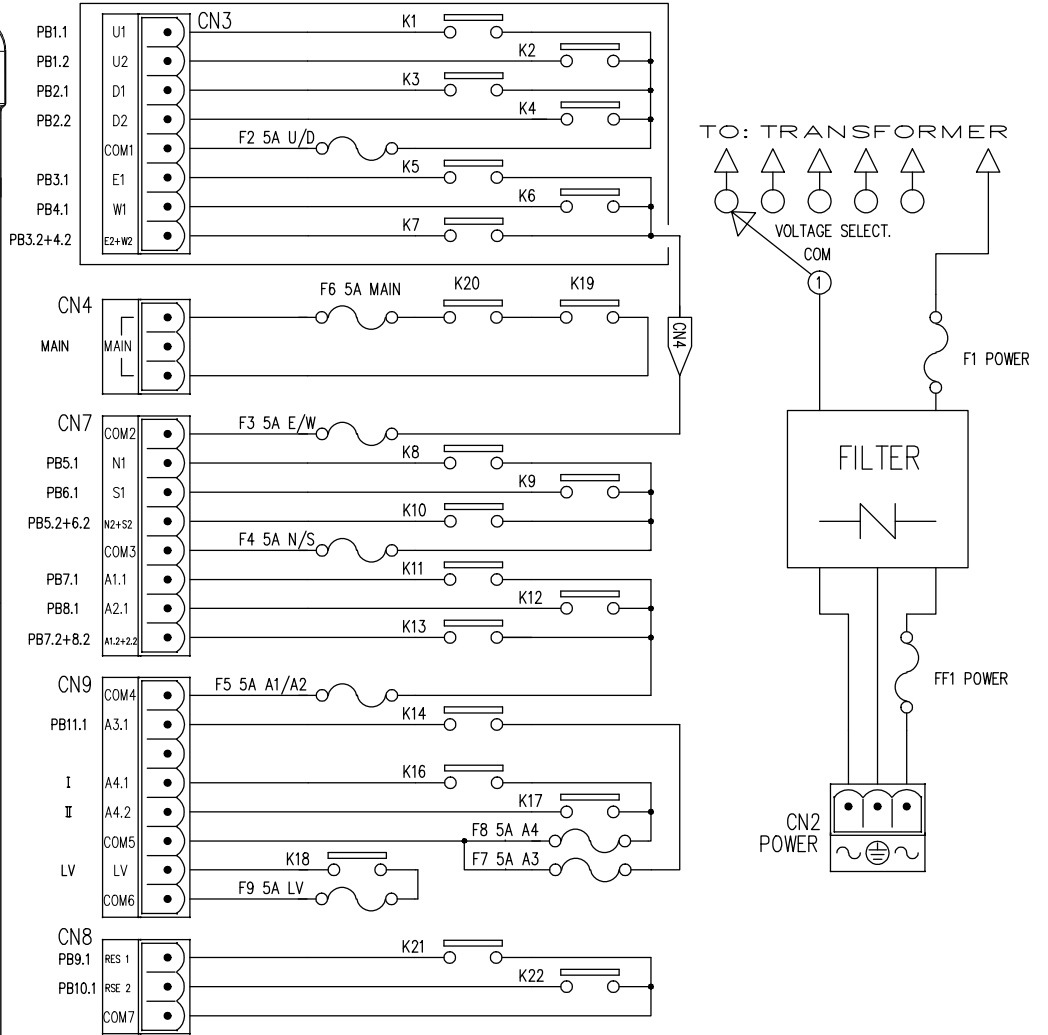



## 6. TRANSMITTER SETTINGS

### 6.1 How to Set ID Codes

6.1.1 Set by programming tool

6.1.2 Set by encoder board 1<sup>st</sup> & 2<sup>nd</sup> pin of JP1 and dip-switch

#### Setting Steps:

- (1) Rotate the transmitter power switch to OFF position.
- (2) Remove the transmitter shock-absorbing rubber.
- (3) Place the transmitter pushbutton side downward and unscrew the transmitter bottom casing.
- (4) Set the transmitter ID code with the dip-switch on the encoder board and put jumper short boot on the 1<sup>st</sup> and 2<sup>nd</sup> pin of JP1.
- (5) Make sure the batteries are installed properly.
- (6) Rotate the transmitter power switch to ON position.
- (7) Green status LED ON for 0.1 sec, OFF for 0.1 sec, flash for 1 sec. (5 times)
- (8) Green status LED steady ON indicates the setting is completed. If the LED status light is changed to red, the setting is failed. Please repeat the above setting steps until the setting is successful.
- (9) After setting is completed and successful, remove jumper from the 1<sup>st</sup> and 2<sup>nd</sup> pin of JP1.
- (10) Rotate transmitter power switch to OFF position.

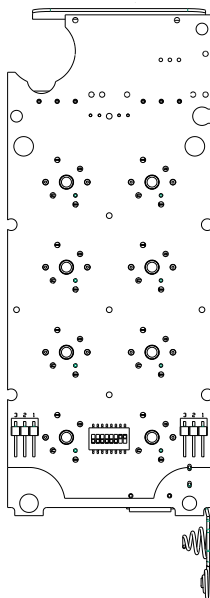

(Fig. 11) Back view

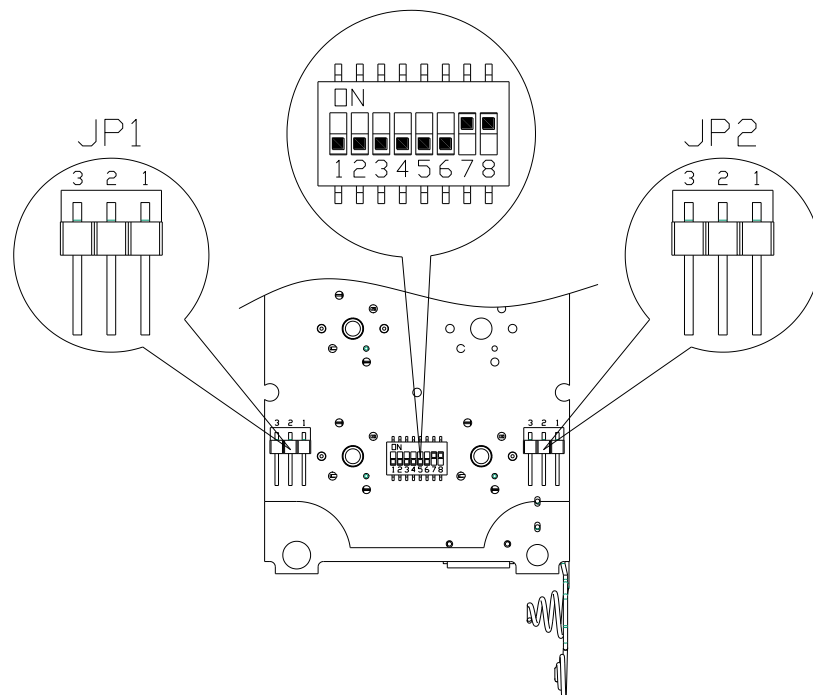

(Fig. 12) Position of dip-switch & jumpers

Top slot ON → “1”; bottom slot → “0”. The setting above is 00000011.

## 6.2 Transmitter Channel Settings

**Transmitter channel settings (Select the channel you would like to operate. Do not exceed the channel limit)**

6.2.1 Set by programming tool

6.2.2 Set by encoder board 2<sup>nd</sup> & 3<sup>rd</sup> pin of JP1 and dip-switch

To set the frequency on JP1 of TX board, put jumper on 2<sup>nd</sup> & 3<sup>rd</sup> pin of JP1. Set the frequency needed by changing the dip-switch setting. Repeat the previous steps to set another frequency.

Example : Set channel as 03→(00000011) → Correct setting



## 7. RECEIVER SETTINGS

### 7.1 How to set a604/607/608/612 Receiver ID Codes

#### 7.1.1 How to set a604/607/608 Receiver ID Codes

Top slot → “1”

Bottom slot → “0”

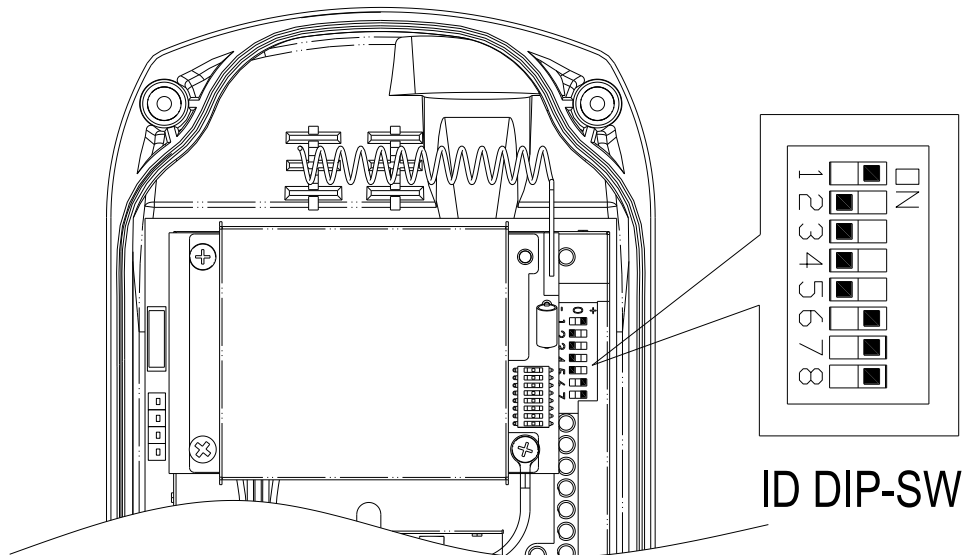

Set the ID codes needed with the dip-switch on the decoder board. For example: the ID codes set above → 1000111.

## 7.1.2 How to set α612 Receiver ID Codes

Please refer to Fig. 10 Internal Parts Assembly (Page 12) for 8-position ID code dip-switch to set receiver ID code.

**Top slot → “1”; bottom slot → “0”**

Set the ID codes needed on the decoder board dip-switch.

For example: the ID codes → 10010110

(“1” value adds up must to be “4”)

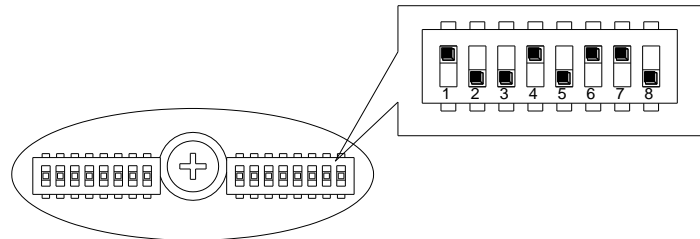

## 7.2 Receiver RF Channel Settings

There are 68 sets of user-adjustable receiving RF channels that can be set manually via an 8-position dip-switch located to the right of the receiving RF module. Change the receiving RF channel simply by resetting the 8-position dip-switch. For the location of the receiving RF module, please refer to fig. 7, 8, and 10 on page 9, 10, and 12.

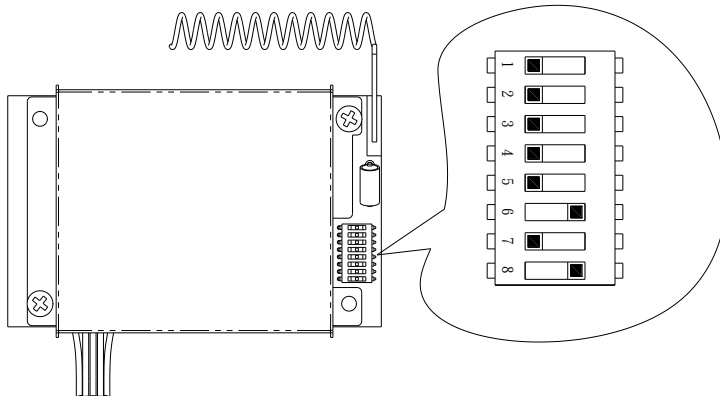

**Top slot → “1”; bottom slot → “0”**

For example : The channel dip-switch set above → 000000101, channel 05.

## 7.3 Receiver Function Settings

### 7.3.1 $\alpha$ 604/607/608 Receiver Function Settings

7.3.1.1 Set by programming tool

7.3.1.2. Adjust the jumper setting function on the decoder board

Adjusting the jumper setting to change the function selection (refer to Jump Set table as below):

	System type	Mode	Description
<b>JP1</b>	$\alpha$ 607A/B/608	Mode 0	Start the system either by pressing the AUX pushbutton (7th pushbutton) or rotating the power switch to "ON" position.
		Mode 1	JP1 setting is invalid under Mode 1. Start the system by rotating the power switch to "ON" position only.
	$\alpha$ 604/607T	Mode 0/1	Start the system by rotating the power switch to "ON" position.
<b>JP2</b>	All	Mode 0	Set the MAIN relay auto shutdown time as 5 minutes or base on customer's single request. The auto shutdown time is set either by the manufacturer or distributor within setting range 0~30 minutes. (default 5 minutes)
	All	Mode 1	JP2 setting is invalid under Mode 1. The MAIN relay auto shutdown time is controlled by the transmitter.
<b>JP3</b>	All	Mode 0/1	1. Refer to "JP3 (*1)" of Jumper Set Table on Page 27 & 28 for $\alpha$ 604A/B, 607A/AT/B/BT and 608A/B. 2. Refer to "JP3(*2), $\alpha$ 608T only" on Page 28, for $\alpha$ 608AT/BT.

#### Receiver function settings:

- The MAIN relay will be activated when system is started. (After the receiver power is started and emergency stop button is elevated)
- The MAIN relay auto shutdown time can be set as 5 minutes or depends on customer's single request. (Remark 1)
- When transmitter voltage is low, relays for the receiver MAIN and LV (Remark 1) will be auto shutdown after one minute.

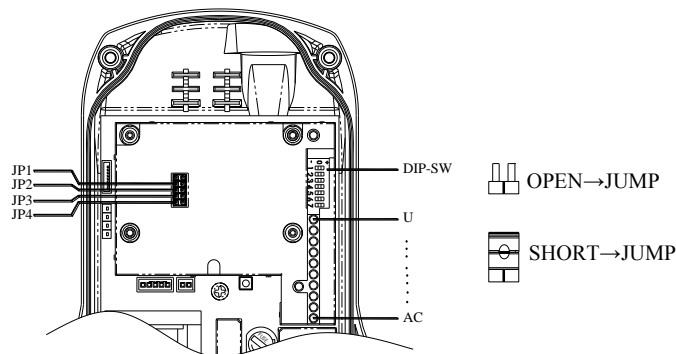

(Fig. 13) Alpha 607, 608 models

Jumper Set table:  in-plant setting (default).

JP1 (Mode 0)	Open	Transmitter AUX pushbutton start (when MAIN relay is off)
	Short	Transmitter power switch start (when MAIN off is off)
JP2 (Mode 0)	Open	No auto shutdown time on Main relay
	Short	The receiver MAIN will be deactivated after consecutive 5 minutes of standby time.

JP3(#1)	Open	When the transmitter voltage is low, LV relay activates/deactivates every second.
	Short	* 4 pushbuttons: When either relay of pushbutton 1~4 is activated, LV relay will also be activated. * 8 pushbuttons: When either relay of pushbutton 1~6 is activated, LV relay will also be activated.
JP3(#2) <b>α608T only</b>	Open	MAIN relay off, I & II relays remain unchanged
	Short	MAIN relay off, I & II relay off.
JP4	Open	7 <sup>th</sup> AUX: “Normal” pushbutton setting
	Short	7 <sup>th</sup> AUX: “Toggle” pushbutton setting

“Start” means: MAIN relay unlatches and then latches.

※ *Open* → *no Jumper*                      *Short* → *put Jumper*

Remark 1 : The setting of auto shutdown time can be done by manufacturer or distributor. Setting range:  
0~30 minutes. (In-plant setting: 5 minutes)

Remark 2 : When the transmitter voltage is low, LV relay will be activated and siren or lights will be ON.  
(One second of interval)

Remark 3 : Every time when you change jumper settings you must first turn the receiver power off and then turn it back on so that the new settings can be stored in memory.

## 7.3.2 α 612 Receiver Function Settings

7.3.2.1 Set by programming tool

7.3.2.2. Adjust Jumper setting function by decoder board

### Receiver function settings:

Jumper Set table:       In-plant setting (default).

JP1 (Mode 0)	Open	Transmitter 11th pushbutton (AUX) start (when MAIN relay is off)
	Short	Transmitter power switch start (when MAIN relay is off)
JP2 (Mode 0)	Open	No auto shutdown time on Main relay
	Short	The receiver MAIN will be deactivated after consecutive 5 minutes of standby time.
JP3	Open	When the transmitter voltage is low, LV relay activates/deactivates every second.
	Short	When either relay of pushbutton 1~8 is activated, LV relay will also be activated.

“Start” means: MAIN relay unlatches and then latches.

Mode 1: 1. JP1 setting is invalid. The system is startup by power switch start.

2. JP2 setting is invalid. The MAIN relay auto shutdown time is set by the transmitter.

※ *Open* → *No jumper*                                      *Short* → *Put Jumper*

Remark 1 : The setting of auto shutdown time can be done by manufacturer or distributor. Setting range:  
0~30 minutes. (In-plant setting: 5 minutes)

※ Prior to jumper setting, be sure to first switch off the system to set.

※ Please take out the batteries from the battery compartment when the transmitter is not operated for a longer time, otherwise the batteries may leak and cause malfunction to the transmitter.

### 7.3.3 Alpha 612 Models Dip-Switch Function Table

Model	Pushbutton	Dip-Switch Setting		Description
612A	1 & 2 3 & 4 5 & 6	DIP 1	→ 1 Not Interlocked	
			→ 0 Interlocked	
	7 & 8	DIP 2	→ 1 Not Interlocked	
			→ 0 Interlocked	
	7 & 8	DIP 3	→ 1 Latching/toggle relay contact	DIP2 must be set at “1”
			→ 0 Momentary relay contact	
	9 & 10	DIP 4	→ 1 Not Interlocked	
			→ 0 Interlocked	
	9	DIP 5	→ 1 Latching/toggle relay contact	DIP4 must be set at “1”
			→ 0 Momentary relay contact	
	10	DIP 6	→ 1 Latching/toggle relay contact	
			→ 0 Momentary relay contact	
612B	7 & 8	DIP 1	→ 1 Not Interlocked	
			→ 0 Interlocked	
	7	DIP 2	→ 1 Latching/toggle relay contact	DIP4 must be set at “1”
			→ 0 Momentary relay contact	
	8	DIP 3	→ 1 Latching/toggle relay contact	DIP4 must be set at “1”
			→ 0 Momentary relay contact	
	9	DIP 4	→ 1 Latching/toggle relay contact	
			→ 0 Momentary relay contact	
612C-1/ 612C-2	1 & 2 (2 <sup>nd</sup> speed)	DIP 1	→ 1 Single contact relay activated	1 <sup>st</sup> and 2 <sup>nd</sup> speed contact relays activated separately
			→ 0 Two contact relays activated	When 2 <sup>nd</sup> speed contact relay is activated, 1 <sup>st</sup> speed contact relay is activated at the same time.
	9	DIP 2,3	→ 00 Momentary relay contact	
		DIP 2,3	→ 01 Latching/toggle relay contact	
		DIP 2,3	→ 10 Reserved	

	10	DIP 4	→ 1 Latching/toggle relay contact		
			→ 0 Momentary relay contact		
<b>612D</b>	1 & 2 (2 <sup>nd</sup> speed)	DIP 1	→ 1 Single contact relay activated	1 <sup>st</sup> and 2 <sup>nd</sup> speed contact relays activated separately	
			→ 0 Two contact relays activated	When 2 <sup>nd</sup> speed contact relay is activated, 1 <sup>st</sup> speed contact relay is activated at the same time.	
	---	DIP 2,3,4	→0 Momentary relay contact	DIP2,3&4 must be set at "0". (In-plant set at "0")	
<b>612E-1/E-2</b>	1 & 2 (2 <sup>nd</sup> speed)	DIP 1	→ 1 Single contact relay activated	1 <sup>st</sup> and 2 <sup>nd</sup> speed contact relays activated separately	
			→ 0 Two contact relays activated	When 2 <sup>nd</sup> speed contact relay is activated, 1 <sup>st</sup> speed contact relay is activated at the same time.	
<b>612E-1</b>	7 & 8	DIP 2	→ 1 Not Interlocked		
			→ 0 Interlocked		
	7	DIP 3	→ 1 Latching/toggle relay contact	DIP2 must be set at "1"	
			→ 0 Momentary relay contact		
	8	DIP 4	→ 1 Latching/toggle relay contact		
			→ 0 Momentary relay contact		
<b>612 A/C-1/C-2/D</b>	11	DIP 7	→ 1 Latching/toggle relay contact		Non-select pushbutton type
			→ 0 Momentary relay contact		
	12	DIP 8	→ 1 Latching/toggle relay contact		
			→ 0 Momentary relay contact		
<b>612 B/E-1/E-2</b>	9	DIP 7	→ 1 Latching/toggle relay contact	Select pushbutton type with 12 <sup>th</sup> button for 3-stage selection. For non-select pushbutton type, 11 <sup>th</sup> & 12 <sup>th</sup> button will be functioned as 9 <sup>th</sup> and 10 <sup>th</sup> button.	
			→ 0 Momentary relay contact		
	10	DIP 8	→ 1 Latching/toggle relay contact		
			→ 0 Momentary relay contact		

※ In-plant all set at "0"

### 7.3.4 Alpha 612 Receiver Voltage Settings

1. Select the voltage for the place where the receiver is installed.
2. Select the position of the “Y” terminal base on the label marked on the transformer.

If the default voltage setting is different from the place where the receiver is installed, please change the setting base on below steps:

- 2.1 Please first refer to below figure. Keep the “COM” end of the wire in the position as it is, remove the “Y” terminal from the other end of the wire, then screw the position originally with “Y” terminal tightly.
- 2.2 Select the voltage needed base on the label of the transformer. Unscrew the position selected, put the “Y” terminal into the position selected and screw it tightly.

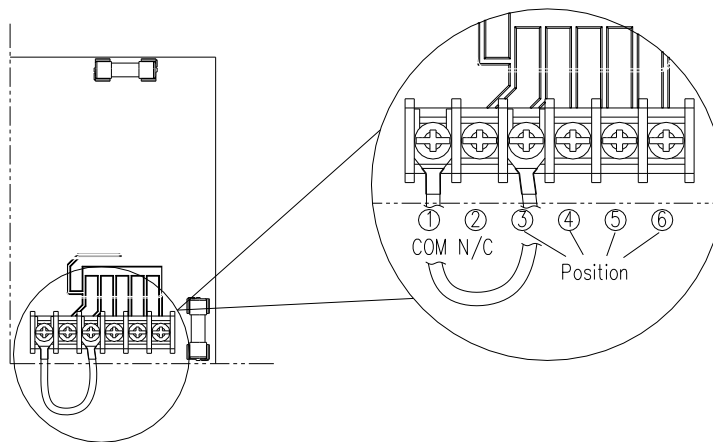

**Transformer type no. :**

**K-2367**

- Position ③ AC 110V → AC 100V ~ AC 125V
- Position ④ AC 240V → AC 200V ~ AC 240V

**Transformer type no. :**

**K-2368**

- Position ⑤ AC 380V → AC 350V ~ AC 380V
- Position ⑥ AC 460V → AC 400V ~ AC 460V

**Transformer type no. :**

**SSB-2665**

- Position ③ AC 25 V
- Position ④ AC 36 V
- Position ⑤ AC 42 V
- Position ⑥ AC 50 V

3. Please make sure that the wire and the 5 screws are securely screwed.



## 7.4 Frequency (RF) Channels Table

Band 301MHz	Dip-Switch Setting	Channel
301.105 MHz	00000001	01
301.130 MHz	00000010	02
301.155 MHz	00000011	03
301.180 MHz	00000100	04
301.205 MHz	00000101	05
301.230 MHz	00000110	06
301.255 MHz	00000111	07
301.280 MHz	00001000	08
301.305 MHz	00001001	09
301.330 MHz	00001010	10
301.355 MHz	00001011	11
301.380 MHz	00001100	12
301.405 MHz	00001101	13
301.430 MHz	00001110	14
301.455 MHz	00001111	15
301.480 MHz	00010000	16
301.505 MHz	00010001	17
301.530 MHz	00010010	18
301.555 MHz	00010011	19
301.580 MHz	00010100	20
<b>301.605 MHz</b>	<b>00010101</b>	<b>21</b>
301.630 MHz	00010110	22
301.655 MHz	00010111	23
301.680 MHz	00011000	24
301.705 MHz	00011001	25
301.730 MHz	00011010	26
301.755 MHz	00011011	27
301.780 MHz	00011100	28
301.805 MHz	00011101	29
301.830 MHz	00011110	30
301.855 MHz	00011111	31
301.880 MHz	00100000	32
301.905 MHz	00100001	33
301.930 MHz	00100010	34

Band 301MHz	Dip-Switch Setting	Channel
301.955 MHz	00100011	35
301.980 MHz	00100100	36
302.005 MHz	00100101	37
302.030 MHz	00100110	38
302.055 MHz	00100111	39
302.080 MHz	00101000	40
302.105 MHz	00101001	41
302.130 MHz	00101010	42
302.155 MHz	00101011	43
302.180 MHz	00101100	44
302.205 MHz	00101101	45
302.230 MHz	00101110	46
302.255 MHz	00101111	47
302.280 MHz	00110000	48
302.305 MHz	00110001	49
302.330 MHz	00110010	50
302.355 MHz	00110011	51
302.380 MHz	00110100	52
302.405 MHz	00110101	53
302.430 MHz	00110110	54
<b>302.455 MHz</b>	<b>00110111</b>	<b>55</b>
302.480 MHz	00111000	56
302.505 MHz	00111001	57
302.530 MHz	00111010	58
302.555 MHz	00111011	59
302.580 MHz	00111100	60
302.605 MHz	00111101	61
302.630 MHz	00111110	62
302.655 MHz	00111111	63
302.680 MHz	01000000	64
302.705 MHz	01000001	65
302.730 MHz	01000010	66
302.755 MHz	01000011	67
302.780 MHz	01000100	68

**NOTE!!! It is prohibited to use Channel 221 and 255.**

<b>Band 433MHz</b>	<b>Dip-Switch Setting</b>	<b>Channel</b>
433.075 MHz	00000001	01
433.100 MHz	00000010	02
433.125 MHz	00000011	03
433.150 MHz	00000100	04
433.175 MHz	00000101	05
433.200 MHz	00000110	06
433.225 MHz	00000111	07
433.250 MHz	00001000	08
433.275 MHz	00001001	09
433.300 MHz	00001010	10
433.325 MHz	00001011	11
433.350 MHz	00001100	12
433.375 MHz	00001101	13
433.400 MHz	00001110	14
433.425 MHz	00001111	15
433.450 MHz	00010000	16
433.475 MHz	00010001	17
434.000 MHz	00010010	18
434.025 MHz	00010011	19
434.050 MHz	00010100	20
434.075 MHz	00010101	21
434.100 MHz	00010110	22
434.125 MHz	00010111	23
434.150 MHz	00011000	24
434.175 MHz	00011001	25
434.200 MHz	00011010	26
434.225 MHz	00011011	27
434.250 MHz	00011100	28
434.275 MHz	00011101	29
434.300 MHz	00011110	30
434.325 MHz	00011111	31
434.350 MHz	00100000	32
434.375 MHz	00100001	33
434.400 MHz	00100010	34

<b>Band 433MHz</b>	<b>Dip-Switch Setting</b>	<b>Channel</b>
434.425 MHz	00100011	35
434.450 MHz	00100100	36
434.475 MHz	00100101	37
434.500 MHz	00100110	38
434.525 MHz	00100111	39
434.550 MHz	00101000	40
434.575 MHz	00101001	41
434.600 MHz	00101010	42
434.625 MHz	00101011	43
434.650 MHz	00101100	44
434.675 MHz	00101101	45
434.700 MHz	00101110	46
434.725 MHz	00101111	47
434.750 MHz	00110000	48
434.775 MHz	00110001	49
433.325 MHz	00110010	50
433.350 MHz	00110011	51
433.375 MHz	00110100	52
433.400 MHz	00110101	53
433.425 MHz	00110110	54
433.450 MHz	00110111	55
433.475 MHz	00111000	56
433.500 MHz	00111001	57
433.525 MHz	00111010	58
433.550 MHz	00111011	59
433.575 MHz	00111100	60
433.600 MHz	00111101	61
433.625 MHz	00111110	62
433.650 MHz	00111111	63
433.675 MHz	01000000	64
433.700 MHz	01000001	65
433.725 MHz	01000010	66
433.750 MHz	01000011	67
433.775 MHz	01000100	68

## 8. TRANSMITTER OPERATION & STATUS LIGHT

### 8.1 Transmitter Operating Steps

#### 1. Battery replacement steps

※※※※ For induction charging, please use two “AA” low self-discharge NiMH (Nickel Metal Hydride) Batteries. ※※※※

A. Screw open the battery cover.

B. Pull up the ribbon (to take out the exhausted batteries)

C. & D. Put and press the first battery into the battery compartment. (Note the polarity and position)

E. & F. Put and press the second battery into the battery compartment. (Note the polarity and position)

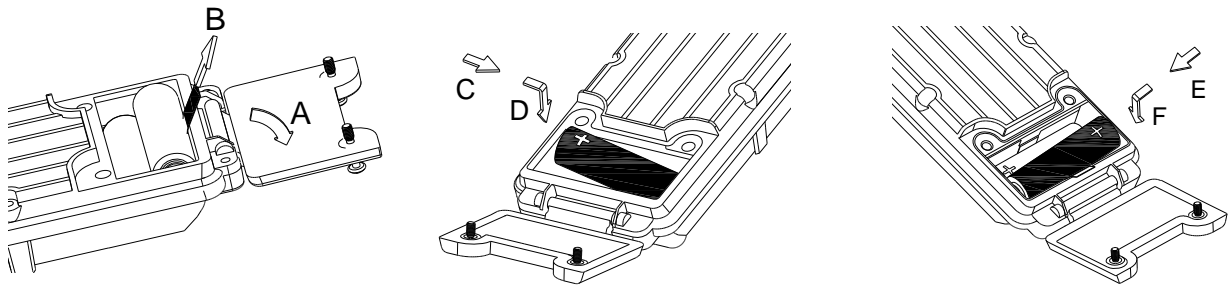

- Status lights** \_To operate the transmitter, please rotate the power key on the top-left corner clockwise to “on” position. The status LED (green and red) will be steady “on” for 2 seconds and then “off”. If the transmitter Status LED displays a red blinking light that is “on” → 0.1 second and “off” → 1.9 seconds, or no light at all, this indicates the transmitter with batteries needs to be recharged. For battery charging or replacement, please refer to instruction next page.
- When any function pushbutton is depressed, the transmitter Status LED displays a green blinking light that is “on”→ 0.1 second and “off”→ 1.9 seconds. If the voltage is low, the transmitter red Status LED will be “on”→0.1 second and “off”→1.9 seconds, this indicates the transmitter with batteries needs to be recharged. Continuous operation will cause the transmitter battery power exhausting and cannot operate at all.
- EMS & Restarting** \_ In case of an emergency, press down the red emergency stop button (EMS) will immediately deactivates the transmitter and receiver MAIN relay. (do not rotate the power switch to OFF first)

Shutting Off the Transmitter(POS) \_ (Mode 0) To disconnect the transmitter power just turn the power key to “off” position. When the power key is switched from “on” to “off”, the transmitter will also send a “Stop” command to the receiver for 3 seconds, the red status light flashes 3 times and at the same time deactivate the MAIN relay.

Shutting Off the Transmitter(POS) \_ (Mode 1) To disconnect the transmitter power just turn the power key to “off” position. When the power key is switched from “on” to “off”, the transmitter will also send a “Stop” command to the receiver for 3 seconds and at the same time deactivate the MAIN relay.

5. The emergency stop button is a right-rotate momentary spring-return type. To turn on the transmitter and activate the MAIN relay, please elevate the emergency stop button again and rotate the transmitter power key to “ON” position.
6. Avoid hitting the transmitter by outer force, so that malfunction can be prevented.
7. The operating temperature is  $-10 \sim +60^{\circ}\text{C}$ . Avoid operating the transmitter in high temperature workshop. If operating temperature is higher than  $80^{\circ}\text{C}$ , the auto shutdown protection installed inside CPU will shut down the transmitter and deactivate the MAIN relay.

Under high temperature protection: Press any pushbutton will send null commands and the corresponding pushbutton relay will be unlatched. In case of high temperature protection functions, please keep the transmitter away from high temperature environment and shut off transmitter power. High temperature protection won't be deactivated only after transmitter is back to operating temperature  $-10 \sim +60^{\circ}\text{C}$  and restarted.

8. To operation normally, the battery power must over 2.2V. If the voltage is lower than 2.2V, the system cannot be started and low voltage will be showed until the MAIN is completely shutdown.
9. If the power voltage is lower than 2.2V when transmitter is operated, the LV code will be “1” and low voltage status light will be shown. For standard system, the transmitter will stop sending signals when voltage is lower than 2.0V. But for EN ISO 13849-1 version, the transmitter will stop sending signals when voltage is lower than 1.8V.

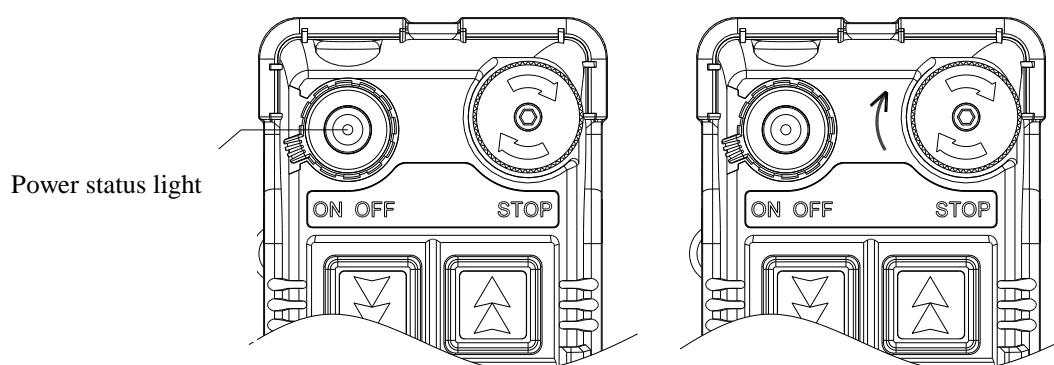

STOP: press → lock (emergency stop)

STOP : Elevate clockwise → reset (Turn on the transmitter at any time)

## 8.2 Transmitter Status Light

Type	Status	Problem	LED Indication
1	Charging	Place transmitter into charger	Constant red light ON
2	Power on when voltage is low	BATT<2.2V	Blinking red light flash ON_0.1/OFF_1.9 sec (until power off)
3	Setting failed or invalidated	Set data by using JUMPER & dip-switch without following rules	Fast blinking on Red light ON_0.1/OFF_0.1 sec

4	Setting completed	JP1 or JP2 inserted	Constant green light ON until transmitter power shuts off.
5	EEPROM ID error	EEPROM ID code does not match CPU data	Constant red light ON until transmitter power shuts off
6	RF module abnormal	PLL UNLOCK	Red light ON_0.1/OFF_0.1 sec
7	ID even number error	Setting error	Red light ON_1/OFF_1 sec
8	Pushbutton locked	Power on pushbutton connected	Red light ON_1.9/OFF_0.1 sec (until power off)
9	Normal power on	BATT $\geq$ 2.2V and all the pushbuttons are not depressed	All the lights ON_2 sec
10	STOP status	STOP button is pressed	MODE 0: Red light ON_0.5/ OFF_0.5sec, flash 30sec. MODE 1: all the lights OFF
11	Low voltage during operation	BATT $<$ 2.2V and press pushbutton	Red light flash ON_0.1/OFF_1.9sec
12	High temperature protection	encoder board temperature higher than 80°C	Press and hold the pushbutton: Blinking blinks ON_0.05/OFF_0.15 second All pushbutton released: All lights are off
13	FSI mode	Activate MSS/FSI function: Depress FAN+SAFETY button and hold for more than 2 seconds.	Blinking red light, green light ON_0.1/OFF_0.1 second
14	Normal operation	Press pushbutton	Green light flash ON_0.1/OFF_1.9 sec

**Remark:**

Under high temperature protection, press every pushbutton will send null commands and the corresponding pushbutton relay will be unlatched. In case of high temperature protection functions, please keep the transmitter away from high temperature environment and shut off transmitter power. High temperature protection won't be deactivated only after the transmitter temperature is back to operating temperature -10 ~ +60°C and restarted.

## 9. RECEIVER INSTALLATION

### 9.1 Preparation for Installation

1. Required Tools for Receiver Installation:

- (1) Flat Head Screwdriver (-)
- (2) Phillips Head Screwdriver (+)
- (3) Multi-Meter
- (4) 14mm Wrench x 2
- (5) Power Drill with  $\varnothing$  10.5mm Drill-Bit

2. Check to ensure that your receiver is not set to the same RF channel and ID code as any other systems in operation at the same facility or within 300-meter distance.
3. Prior to installation, make sure that the crane or equipment itself is working properly.
4. Use a multi-meter to check the voltage source available and ensure the receiver voltage setting matches your power source.
5. Prior to installation, switch off the main power source to the crane or equipment.

## **9.2 Step By Step Installation and Commissioning**

### **9.2.1 Select the location**

Select the location for installation and wiring: (*Attention!!!*)

#### **α604/607/608**

1. For better reception, the location selected should have the antenna visible from all areas where the transmitter is to be used.
2. The location selected should not be exposed to high levels of electrical noise. Mounting the receiver next to an unshielded variable frequency control (inverter) may cause minor interference.
3. If it is unavoidable, please consider using antenna with external coaxial cable to relocate the antenna to better signal receipt position.
4. Always locate the receiver unit as far away from high voltage wiring or equipment, such as: motor, relay, magnetic valve, inverter controls and output cable...etc. as possible. Be sure to install the receiver at least 2 meters away from the inverter. If the receiver is installed on the control box, then the antenna position has to be higher than the control box. (as Fig.14)

#### **α612**

Drill four holes (dia.10.5mm) base on the position of the receiver shock absorbers. (Fig.15)

### **9.2.2 Commissioning steps**

1. Decide the wiring type and cable. If the cable gland is used for the cable, please use the enclosed rubber cork to seal the cable gland without cable.
2. For system wiring, please refer to the output contact diagrams from page 13.
3. Ensure the selected location has adequate space to accommodate the receiver enclosure.
4. Make sure the receiver unit is in upright position (vertical).

**NOTE!! The distance between the antenna and the control panel should be as far apart as possible** (refer to the fig.14 & 15).

5. If a crane or equipment's runway is longer than 100 meters, an external antenna should be added. The Alpha 608 receiver housing has provisions for an external factory installed antenna available as

an option, contact your dealer for price and delivery.

6. Drill a hole on the control panel (10.5mm)

7. Tightened the bolt nuts provided.

**8. If the control panel has a plastic surface, extended grounding wire should be used.**

9. Ensure all wiring is correct and safely secured and all screws are fastened.

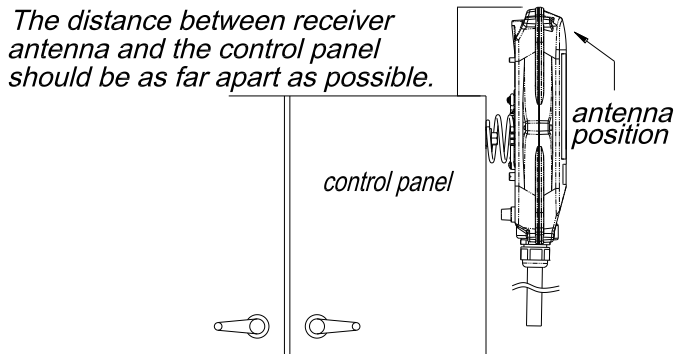

(Fig.14) Alpha 604, 607, 608 Models

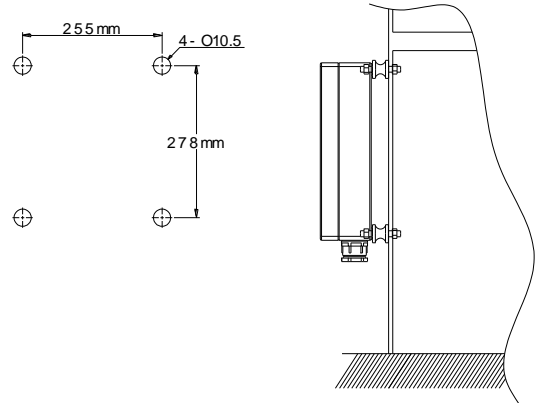

(Fig.15) Alpha 612 Models

### 9.3 System Testing

1. Connect the power source to the receiver and test the MAIN relay output by pressing the red emergency stop button (EMS) and observe that it properly opens and closes the main line disconnect contactor.
2. Test the operation of each function to ensure it corresponds to the transmitter direction labels and/or the pendant it is replacing.
3. Test the limit switches on the hoist and/or crane and verify they are working properly.
4. If your new remote control is replacing an existing pendant, make sure it is completely disconnected to prevent unwanted control commands, i.e. snick circuits.
5. If your new remote control is replacing an existing pendant make sure it is stored in a safe location where it will not interfere with remote operation (get torn off).

### 9.4 Receiver system Status LED Display

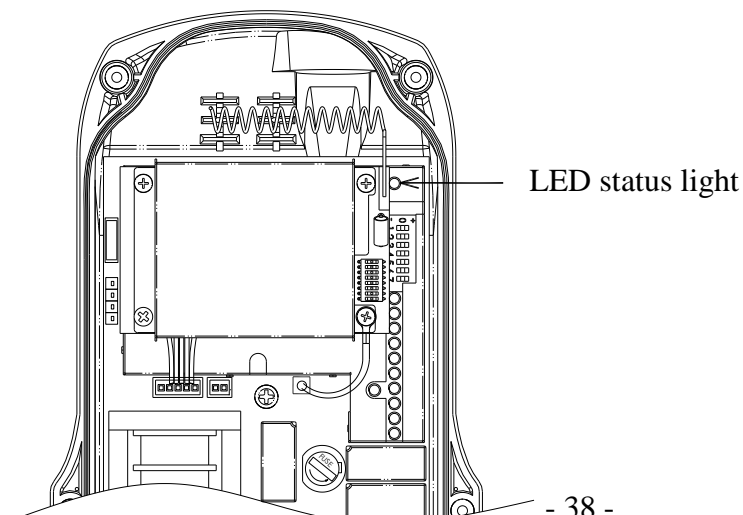

## Receiver system Status LED Display

Type	Led Indication	Problem and Solution
1	Constant red light.	EEPROM error – reprogramming required.
		Incorrect receiver ID code setting (see note below).
2	ON → 1.0 second OFF → 1.0 second	ID code not matched on both the transmitter and receiver unit, please readjust accordingly.
3	Dim or no light.	Under-voltage, check the main power-supply.
4	ON → 2.0 seconds OFF → 0.1 second	MAIN contact relay jammed or defective.
5	ON → 0.1 second OFF → 2.0 seconds	System normal with transmitter pushbutton either in neutral or in transmitter power “off” position.
6	ON → 0.1 second OFF → 0.1second	System normal with transmitter pushbutton in non-neutral position (pushbutton depressed).

Note: Please refer to section 7.1 on page 25 for correct ID code setting.

## Alpha 612 Receiver System Status LED Display

Led Indication		Reason	Solution
Power LED display	ON	Normal-voltage	
	OFF	Under-voltage	
SQ, Status LED display	ON	Transmitted signals detected and received	
	OFF	No transmitting signal detected	
	BLINK	1. Transmitter standby	Turn on the transmitter
		2. Interference	Turn off the transmitter
Relay LED display	ON	Normal operation	
	OFF	Receiver defective	Repair decoder board



## 10. BATTERY CHARGER

### 10.1 Charger Operation

#### Electromagnetic Induction Charge

- The electromagnetic induction charger with undisclosed metal charging contacts on transmitter provides immediate charging simply by sliding the transmitter into the charger. It is not necessary to open the battery cover to replace batteries.
- To avoid rain, high temperature, humidity and corroding air, please place or install the battery charger indoor with good ventilation. Keep 5cm space for two sides of the charger to keep the heat out. The suggesting temperature range is 0 ~ 40°C.

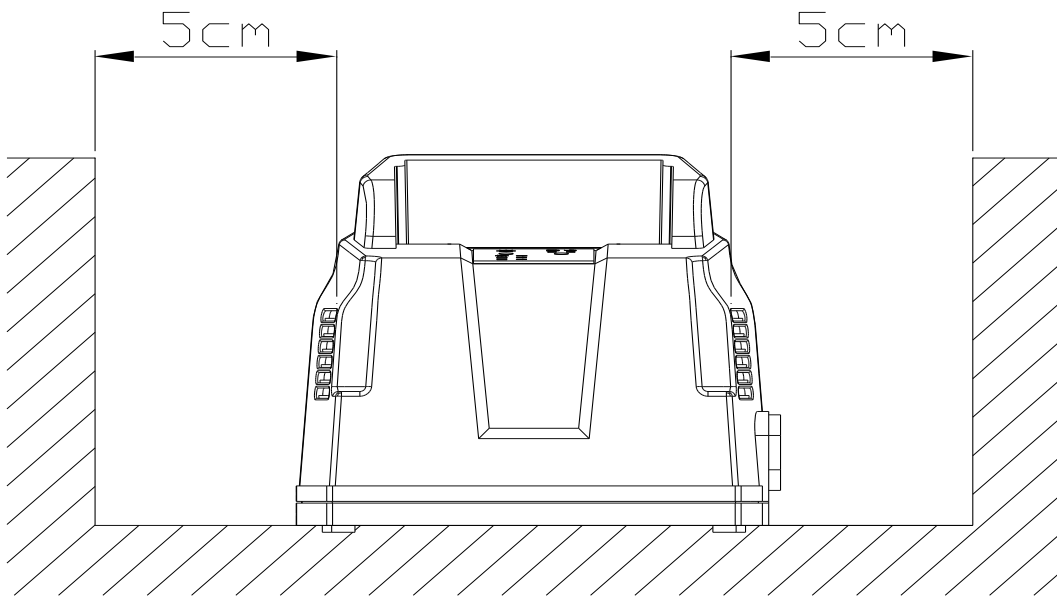

(Fig. 16) Front view

- Battery charger voltage AC100~240V 50/60Hz, power consumption 10W ◦
- Use Nickel-Metal low self-discharge Hydride (NI-MH) 2000mA, AA size\*2 rechargeable batteries. Charging can be completed in 4 hours.
- Set the power switch on the OFF position whenever transmitter is not operated. Press E-STOP button and slide-in the transmitter into the charger to charge. The transmitter is suggested to be charged whenever it is not operated. The power switch should be rotated to OFF position while charging, otherwise charging cannot be proceeded.
- The charger status light shows red when transmitter is charging; transmitter status light will be off when charging is completed or failed. Please refer to below Battery Charger LED Status Light for details. The charger status light shows green when charging is completed.
- When the rechargeable batteries are placed under low temperature environment, the activity is low and the “charging completed” LED will display in a shorter time than usual. To avoid such condition, please recharge the batteries within 0 ~ 40°C. Under lower temperature environment (below 0°C), the running down batteries will complete charging within half an hour. That means the charging is

completed earlier than scheduled. Please take out the transmitter from charger and insert it into charger again to proceed with charging normally.

- If the rechargeable batteries are not used for a longer period of time, the charging will be completed in a shorter time than usual. To charge normally, please take out the transmitter from charger and insert it into charger again.
- Please change the two rechargeable batteries at the same time to charge or discharge completely.
- Charger power LED: green

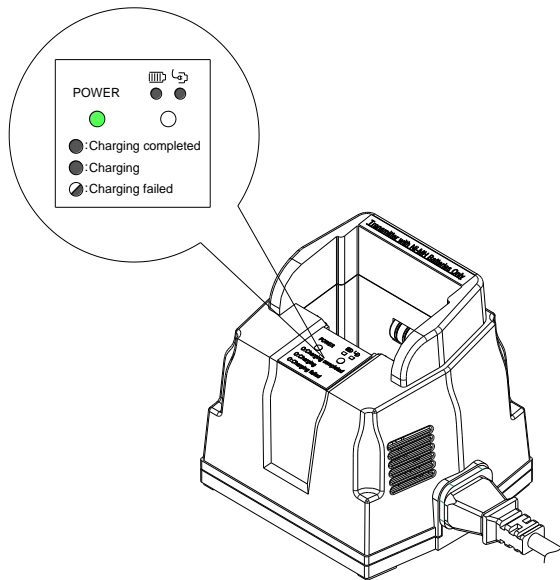

Slide-in transmitter into battery charger (transmitter vinyl protective cover has to be taken off)

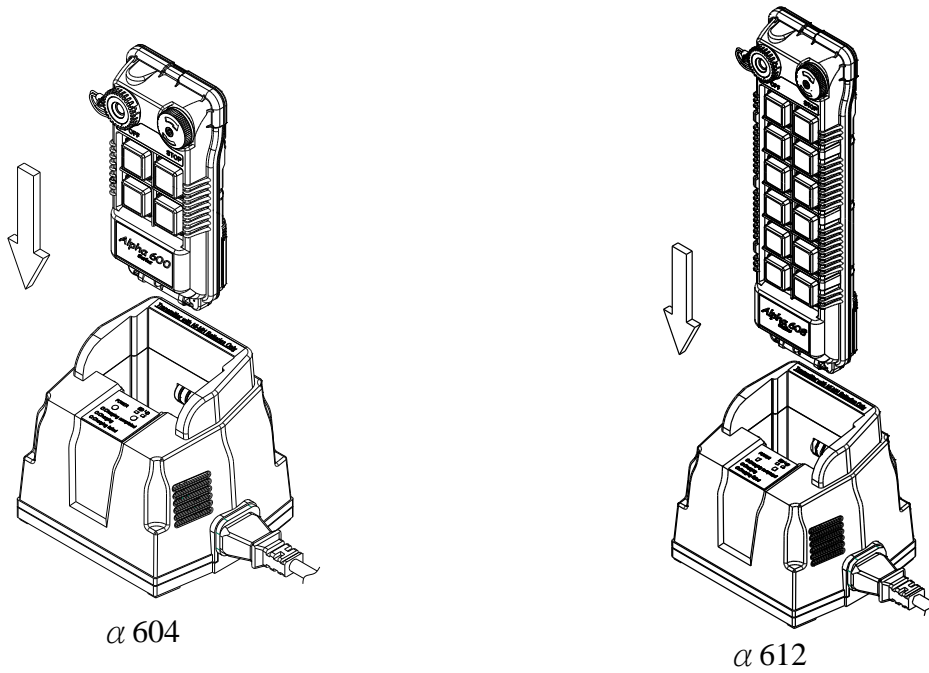

※ *Note: The rechargeable battery has to be recharged within 6 months after the manufacturing date.*

## 10.2 Battery Charger LED Status Light

Item	Status	Condition	Status Light
1	Startup check	Within 2 seconds after power is on	Red + Green LED for 2 sec
2	Charging failed	No battery inside transmitter battery holder or non-rechargeable battery is used.	Red LED OFF_0.1/ON_1.9 sec
3	Charging	Charging procedure is normal	Red LED ON
4	Charging completed	Charging procedure is completed	Green LED ON
5	Standby	No transmitter in the charger	Not lit

## 11. TROUBLE SHOOTING

Should the operator find the equipment not operating normally, please check the chart below for simple trouble shooting tips.

Problem	Possible Reason	Solution
Transmitter does not communicate with the receiver.	Transmitter and the receiver are not on the same RF channel (SQ lamp not lit) or ID code.	Ensure the correct transmitter is in use. The labels on the receiver and the transmitter will identify the RF channel and ID code in use.
Transmitter does not communicate with the receiver.	Low or no transmitting power from the transmitter unit.	Turn “on” the transmitter with EMS elevated. If the status LED shows blinking red light or no light at all, then turn the power “off” and replace the two alkaline “AA” batteries.
No power to the receiver (AC power indicator on the receiver unit not lit).	Blown fuse or no input power connection.	Ensure power input to the receiver unit is correct. If the power indicator (AC) is still not lit, please check the receiver for any open fuse.
Outputs do not operate correctly.	Receiver configuration is not set properly or output wiring is incorrect.	Please refer to section 6 and 7 to ensure receiver is correctly wired and configured for your application.
Transmitter does not communicate with the receiver.	Transmitter is turned on with the EMS activated (pressed down).	Elevate the EMS first and then turn the power switch off and then on again.

## 12. SYSTEM SPECIFICATION

### Transmitter Unit

Source Voltage	:	Ni-MH AA size x 2 batteries 2.4V (no contact charging) Or AA size alkaline x 2 batteries 3.0V
Antenna Impedance	:	Internal Antenna 50 ohms. External antenna is available.
Dimension	:	604 Models : 140mm x 68mm x 30mm 607, 608 Models: 189mm x 68mm x 30mm 612 Models : 235mm x 68mm x 30mm
Weight	:	604 Models : 220g (include batteries) 607, 608 Models: 280g (include batteries) 612 Models : 350g (include batteries)
Enclosure Rating	:	IP-65
Operating Temperature	:	-10 ~ +60°C (> 80°C high temperature protection )
Transmitting Power Consumption	:	≤ 20mA@3V (Various from encoding mode and transmitting power) ≤ 30mA@3V (Various from encoding mode and transmitting power) Alpha 612B /Alpha 612E-1/Alpha 612E-2
Continue Operating Time	:	> consecutive 100hrs @batteries full (2000mA), Band 301, 433MHz, Transmitting Power 1mW
Low Voltage	:	2.2V – 2.0V

### Transmitting RF Board Unit

Frequency Range	:	301, 433 MHz
Transmitting Power	:	0.1 mW – 10mW
Frequency Control	:	VTCXO ( PLL)
Frequency Deviation	:	< 1ppm @ 25°C
Spurious Emission	:	< - 50dB
Emission	:	F1D
Antenna Impedance	:	50 ohms
Operating Temperature	:	-10°C ~ +60°C

### Charger Unit

Dimension	:	120mm x 105mm x 105mm
Voltage	:	100~240V 50/60Hz
Power Consumption	:	Max.10 Watt
Operating Temperature	:	0°C ~ +40°C
Heat Ventilation	:	Temperature Control Fan
Charging Current	:	About 600mA @3V
Charging Time	:	About 3~4hrs @2000mAh
Charging Detection	:	-ΔV + Temperature

## Receiver Unit

Frequency Band	:	BRXN – 301, 433 MHz
Channel Spacing	:	25KHz (BRX-301, 433)
Frequency Control	:	VTCXO (PLL)
Frequency Drift	:	< 5ppm @ -20°C ~ +70°C
Frequency Deviation	:	< 1ppm @ 25°C
Sensitivity		<-115dBm
Spurious Emission	:	- 50dB
Antenna Impedance	:	50 ohms
Responding Time		40ms (Normal)
Enclosure Rating	:	IP-65
Source Voltage	:	<b>α604/607/608:</b> DC12V-24V, AC48V, AC110V, AC220V, AC230V, AC240, AC380V Full voltage module: AC100-240V @50/60Hz <b>α612:</b> DC12V-24V, AC24/32/36/48V, AC110V/240V, AC380-460V @50/60Hz
Power Consumption		α604: 8 Watt α607/8: 10 Watt α612: 15 Watt
Operating Temperature	:	-10°C ~ +70°C
Output Contact Rating		250V @ 5A
Dimension		604 Models : 310mm x 134mm x 72mm 607, 608 Models: 310mm x 134mm x 72mm 612 Models : 300mm x 230mm x 86mm
Weight	:	604 Models : 1,770g (include output cable) 607, 608 Models: 2,022g (include output cable) 612 Models : 3,500g (include output cable)

## 13. PARTS LIST

### Transmitter

1. Transmitter RF module (All models)	BTXN433
2. Encoder board (Alpha 604A)	BEN604A
Encoder board (Alpha 604B)	BEN604B
Encoder board (Alpha 607A)	BEN607A
Encoder board (Alpha 607B)	BEN607B
Encoder board (Alpha 607AT)	BEN607AT
Encoder board (Alpha 607BT)	BEN607BT
Encoder board (Alpha 608A)	BEN608A
Encoder board (Alpha 608B)	BEN608B
Encoder board (Alpha 608AT)	BEN608AT
Encoder board (Alpha 608BT)	BEN607BT
Encoder board (Alpha 612A)	BEN612A
Encoder board (Alpha 612B)	BEN612B
Encoder board (Alpha 612C-1)	BEN612C-1
Encoder board (Alpha 612C-2)	BEN612C-2
Encoder board (Alpha 612D)	BEN612D
Encoder board (Alpha 612E-1)	BEN612E-1
Encoder board (Alpha 612E-2)	BEN612E-2
3. Transmitter enclosure (Alpha 604)	BCT604
Transmitter enclosure (Alpha 607 & 608)	BCT607
Transmitter enclosure (Alpha 612)	BCT612
4. Battery cover	BC600
5. 2-step pushbutton	B50001
1-step pushbutton	B50002
6. EMS red cap (All models)	EMS01
7. EMS pushbutton mechanism (All models, red cap included)	B50003
8. Pushbutton rubber boot fixing holder (Alpha 604)	BFH604
Pushbutton rubber boot fixing holder (Alpha 607 & 608)	BFH607/608
Pushbutton rubber boot fixing holder (Alpha 612)	BFH612
9. Pushbutton rubber boot (Alpha 604)	PRB01
Pushbutton rubber boot (Alpha 607 & 608)	PRB02
Pushbutton rubber boot (Alpha 612)	PRB03
10. Transmitter shock-absorbing rubber (All models)	SAR02
11. Transmitter vinyl protective cover (Alpha 604)	VPC01
Transmitter vinyl protective cover (Alpha 607 & 608)	VPC02
Transmitter vinyl protective cover (Alpha 612)	VPC03
12. A600 waist strap (All models)	WS01
13. Ni-MH AA rechargeable battery	RCB01
Alkaline AA battery	ALB01
14. A600 pushbutton direction label	DL01

### Receiver

1. 433MHz receiver RF module (All models)	<b>Part No.</b> BRX433
2. Decoder board (Alpha 604A)	BDE604A
Decoder board (Alpha 604B)	BDE604B
Decoder board (Alpha 607A)	BDE607A
Decoder board (Alpha 607B)	BDE607B
Decoder board (Alpha 607AT)	BDE607AT
Decoder board (Alpha 607BT)	BDE607BT
Decoder board (Alpha 608A)	BDE608A
Decoder board (Alpha 608B)	BDE608B
Decoder board (Alpha 608AT)	BDE608AT

Decoder board (Alpha 608BT)	BDE608BT
Decoder board (Alpha 612A)	BDE612A
Decoder board (Alpha 612B)	BDE612B
Decoder board (Alpha 612C-1)	BDE612C-1
Decoder board (Alpha 612C-2)	BDE612C-2
Decoder board (Alpha 612D)	BDE612D
Decoder board (Alpha 612E-1)	BDE612E-1
Decoder board (Alpha 612E-2)	BDE612E-2
3. Receiver enclosure (Alpha 604/607/608)	BCR607
Receiver enclosure (Alpha 612)	BCR612
4. Receiver mounting spring (Alpha 604/607/608)	RMS600
5. Regular Output Contact Relay-blue (All Models)	RLY01
6. Safety MAIN Contact Relay-DC12V (All Models)	RLY02
7. Transformer (12-24VDC – Alpha 600-608, 612)	T24VDC
Transformer (48VAC – Alpha 600-608)	T48VAC
Transformer (110VAC – Alpha 600-608)	T110VAC
Transformer (220VAC – Alpha 600-608)	T220VAC
Transformer (230VAC – Alpha 600-608)	T230VAC
Transformer (240VAC – Alpha 600-608)	T240VAC
Transformer (380VAC – Alpha 600-608)	T380VAC
Transformer (25/36/42/50VAC – Alpha 612)	T25/36/42/50VAC
Transformer (110/240VAC – Alpha 612)	T110/240VAC
Transformer (380/460VAC – Alpha 612)	T380/460VAC
8. Full voltage module (100-240VAC-Alpha 600-608)	FV100-240VAC
9. 2-meter Output Cable with 5 Common Circuits Cable (24C*2m V3.5, Alpha 607, 608)	OC607
10. Optional External 433 MHz Antenna (All Models)	ANT433

### **Charger/USB programming parts**

1. Charging board	CHPCB600
2. Electromagnetic board	ELEPCB
3. Charger casing	CHC600
4. Charging cable	CHCA
5. Charger holder	CHH600
6. USB programming board	USBPCB
7. USB connecting cable (1m)	USBC